

SG67412



Description

- A complete spectrum of compact residual current devices for a wide range of applications
- For fault current/residual current protection and additional protection
- Wide variety of nominal currents
- Comprehensive range of accessories
- Real contact position indicator

Supplied by Digital Stout Innovation & Trading FZE UAE

$I_n/I_{\Delta n}$ (A)	Type Designation	Article No.	Units per package
---------------------------	---------------------	-------------	----------------------

Type AC

Conditionally surge current-proof 250 A, type AC 

SG68312



2-pole

16/0.01	mRCM-16/2/001	158049	1/60
16/0.03	mRCM-16/2/003	142748	1/60
25/0.03	mRCM-25/2/003	142750	1/60
25/0.1	mRCM-25/2/01	142752	1/60
25/0.3	mRCM-25/2/03	142754	1/60
40/0.03	mRCM-40/2/003	142756	1/60
40/0.10	mRCM-40/2/01	142758	1/60
40/0.30	mRCM-40/2/03	142760	1/60
63/0.03	mRCM-63/2/003	142762	1/60
63/0.10	mRCM-63/2/01	142764	1/60
63/0.30	mRCM-63/2/03	142766	1/60
80/0.03	mRCM-80/2/003	142768	1/60
80/0.10	mRCM-80/2/01	142770	1/60
80/0.30	mRCM-80/2/03	142772	1/60
100/0.03	mRCM-100/2/003	142774	1/60
100/0.10	mRCM-100/2/01	142776	1/60
100/0.30	mRCM-100/2/03	142778	1/60

SG67412



4-pole

25/0.03	mRCM-25/4/003	142781	1/30
25/0.1	mRCM-25/4/01	142783	1/30
25/0.3	mRCM-25/4/03	142785	1/30
40/0.03	mRCM-40/4/003	142787	1/30
40/0.10	mRCM-40/4/01	142789	1/30
40/0.30	mRCM-40/4/03	142791	1/30
63/0.03	mRCM-63/4/003	142793	1/30
63/0.10	mRCM-63/4/01	142795	1/30
63/0.30	mRCM-63/4/03	142797	1/30
80/0.03	mRCM-80/4/003	142799	1/30
80/0.10	mRCM-80/4/01	142801	1/30
80/0.30	mRCM-80/4/03	142803	1/30
100/0.03	mRCM-100/4/003	142805	1/30
100/0.10	mRCM-100/4/01	142807	1/30
100/0.30	mRCM-100/4/03	142809	1/30

Supplied by Digital Stout Innovation Consulting FZE UAE

$I_n/I_{\Delta n}$ (A)	Type Designation	Article No.	Units per package
---------------------------	---------------------	-------------	----------------------

Type A

Conditionally surge current-proof 250 A, sensitive to residual pulsating DC, type A

SG68312



2-pole

16/0.01	mRCM-16/2/001-A	158060	1/60
16/0.03	mRCM-16/2/003-A	142749	1/60
25/0.03	mRCM-25/2/003-A	142751	1/60
25/0.1	mRCM-25/2/01-A	142753	1/60
25/0.3	mRCM-25/2/03-A	142755	1/60
40/0.03	mRCM-40/2/003-A	142757	1/60
40/0.10	mRCM-40/2/01-A	142759	1/60
40/0.30	mRCM-40/2/03-A	142761	1/60
63/0.03	mRCM-63/2/003-A	142763	1/60
63/0.10	mRCM-63/2/01-A	142765	1/60
63/0.30	mRCM-63/2/03-A	142767	1/60
80/0.03	mRCM-80/2/003-A	142769	1/60
80/0.10	mRCM-80/2/01-A	142771	1/60
80/0.30	mRCM-80/2/03-A	142773	1/60
100/0.03	mRCM-100/2/003-A	142775	1/60
100/0.10	mRCM-100/2/01-A	142777	1/60
100/0.30	mRCM-100/2/03-A	142779	1/60

SG67412



4-pole

16/0.03	mRCM-16/4/003-A	142780	1/30
25/0.03	mRCM-25/4/003-A	142782	1/30
25/0.1	mRCM-25/4/01-A	142784	1/30
25/0.3	mRCM-25/4/03-A	142786	1/30
40/0.03	mRCM-40/4/003-A	142788	1/30
40/0.10	mRCM-40/4/01-A	142790	1/30
40/0.30	mRCM-40/4/03-A	142792	1/30
63/0.03	mRCM-63/4/003-A	142794	1/30
63/0.10	mRCM-63/4/01-A	142796	1/30
63/0.30	mRCM-63/4/03-A	142798	1/30
80/0.03	mRCM-80/4/003-A	142800	1/30
80/0.10	mRCM-80/4/01-A	142802	1/30
80/0.30	mRCM-80/4/03-A	142804	1/30
100/0.03	mRCM-100/4/003-A	142806	1/30
100/0.10	mRCM-100/4/01-A	142808	1/30
100/0.30	mRCM-100/4/03-A	142810	1/30

Supplied by Digital Stout Innovation Consulting FZE UAE

$I_n/I_{\Delta n}$ (A)	Type Designation	Article No.	Units per package
---------------------------	---------------------	-------------	----------------------

Type G

Surge current-proof 3 kA, type G (ÖVE E 8601) 

SG68312



2-pole

25/0.03	mRCM-25/2/003-G	167024	1/60
40/0.03	mRCM-40/2/003-G	168645	1/60

SG67412



4-pole

40/0.03	mRCM-40/4/003-G	167025	1/30
63/0.03	mRCM-63/4/003-G	167026	1/30
80/0.03	mRCM-80/4/003-G	167027	1/30
100/0.03	mRCM-100/4/003-G	180407	1/30

Type S/A

Selective + surge current-proof 5 kA, sensitive to residual pulsating DC, type S/A 

SG66312



2-pole

40/0.10	mRCM-40/2/01-S/A	180412	1/60
---------	------------------	--------	------

SG67412



4-pole

40/0.30	mRCM-40/4/03-S/A	180408	1/30
63/0.30	mRCM-63/4/03-S/A	180409	1/30
80/0.30	mRCM-80/4/03-S/A	180410	1/30
100/0.30	mRCM-100/4/03-S/A	180411	1/30

Specifications | Residual Current Devices mRCM

Description

- Residual Current Devices
- Shape compatible with and suitable for standard busbar connection to other devices
- Twin-purpose terminal (lift/open-mouthed) above and below
- Busbar positioning optionally above or below
- Free terminal space despite installed busbar
- Universal tripping signal switch, also suitable for MCB, RCBO, ... can be mounted subsequently
- Auxiliary switch Z-HK can be mounted subsequently
- Contact position indicator red - green
- Delayed types suitable for being used with standard fluorescent tubes with or without electronical ballast (30mA-RCD: 30 units per phase conductor, 100mA-RCD: 90 units per phase conductor).
Notes: Depending of the fluorescent lamp ballast manufacturer partly more possible. Symmetrical allocation of the fluorescent lamp ballasts on all phases favourably. Shifting references of the fluorescent lamp ballast manufacturer consider.
- The device functions irrespective of the position of installation
- Tripping is line voltage-independent. Consequently, the RCD is suitable for "fault current/residual current protection" and "additional protection" within the the meaning of the applicable installation rules
- Mains connection at either side
- The 4-pole device can also be used for 2- or 3-pole connection. See connection possibilities.
- The test key "T" must be pressed every 6 month. The system operator must be informed of this obligation and his responsibility in a way that can be proven (self-adhesive RCD-label enclosed). The test intervall of 6 month is valid for residential and similar applications. Under all other conditions (e.g. damply or dusty environments), it's recommended to test in shorter intervalls (e.g. monthly).
- Pressing the test key "T" serves the only purpose of function testing the residual current device (RCD). This test does not make earthing resistance measurement (R_E), or proper checking of the earth conductor condition redundant, which must be performed separately.

- **Type -A:** Protects against special forms of residual pulsating DC which have not been smoothed
- **Type -G:** High reliability against unwanted tripping. Compulsory for any circuit where personal injury or damage to property may occur in case of unwanted tripping (ÖVE/ÖNORM E 8001-1 § 12.1.6)
- **Type -G/A:** Additionally protects against special forms of residual pulsating DC which have not been smoothed
- **Type -S:** Selective residual current device sensitive to AC, type -S. Compulsory for systems with surge arresters downstream of the RCD (ÖVE/ÖNORM E 8001-1 § 12.1.5).
- **Type -S/A:** Additionally protects against special forms of residual pulsating DC which have not been smoothed

Accessories:

Auxiliary switch for subsequent installation to the left	Z-HK	248432
Tripping signal contact for subsequent installation to the right	Z-NHK	248434
Remote control and automatic switching device	Z-FW/LP	248296
Compact enclosure	KLV-TC-2	276240
	KLV-TC-4	276241
Sealing cover set	Z-RC/AK-2TE	285385
	Z-RC/AK-4MU	101062

Technical Data

		mRCM	
Electrical			
Design according to		IEC/EN 61008 Type G according to ÖVE E 8601	
Current test marks as printed onto the device			
Tripping		instantaneous	
Type G		10 ms delay	
Type S		40 ms delay - selective disconnecting function	
Rated voltage	U_n	230/400 V AC, 50 Hz	
Rated tripping current	$I_{\Delta n}$	10, 30, 100, 300, 500 mA	
Sensitivity		AC and pulsating DC	
Rated insulation voltage	U_i	440 V	
Rated impulse withstand voltage	U_{imp}	4 kV (1.2/50 μ s)	
Rated short circuit strength	I_{cn}	10 kA	
Maximum back-up fuse		Short circuit	Overload
$I_n = 16$ A		63 A gG/gL	10 A gG/gL
$I_n = 25$ A		63 A gG/gL	16 A gG/gL
$I_n = 40$ A		63 A gG/gL	25 A gG/gL
$I_n = 63$ A		63 A gG/gL	40 A gG/gL
$I_n = 80$ A		80 A gG/gL	50 A gG/gL
$I_n = 100$ A		100 A gG/gL	63 A gG/gL
In the case that the maximal possible operating current of the electrical installation don't exceed the rated current of the RCD only short circuit protection must be implemented. Overload protection must be implemented in the case if the maximal possible operating current of the electrical installation can exceed the rated current of the RCD.			
Rated breaking capacity	I_m		
Rated fault breaking capacity	$I_{\Delta m}$		
$I_n = 16-40$ A		500 A	
$I_n = 63$ A		630 A	
$I_n = 80$ A		800 A	
$I_n = 100$ A		1000 A	
Voltage range of test button			
2-pole		196 - 264 V~	
4-pole 30 mA		196 - 264 V~	
4-pole 10, 100, 300, 500 mA		196 - 456 V~	
Endurance			
electrical components		$\geq 4,000$ switching operations	
mechanical components		$\geq 20,000$ switching operations	
Mechanical			
Frame size		45 mm	
Device height		80 mm	
Device width		35 mm (2MU), 70 mm (4MU)	
Mounting		quick fastening with 2 lock-in positions on DIN rail IEC/EN 60715	
Degree of protection, built-in		IP40	
Degree of protection in moisture-proof enclosure		IP54	
Upper and lower terminals		open mouthed/lift terminals	
Terminal protection		finger and hand touch safe, DGUV VS3, EN 50274	
Terminal capacity		1.5 - 35 mm ² single wire 2 x 16 mm ² multi wire	
Terminal screw		M5 (mit geschlitzter Schraube according to EN ISO 4757-Z2, Pozidriv PZ2)	
Terminal torque		2 - 2.4 Nm	
Busbar thickness		0.8 - 2 mm	
Tripping temperature		-25°C to +40°C	
Storage- and transport temperature		-35°C to +60°C	
Resistance to climatic conditions		25-55°C/90-95% relative humidity according to IEC 60068-2	

Connection diagrams

2-pole

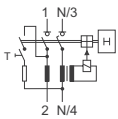

4-pole

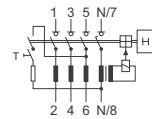

Dimensions (mm)

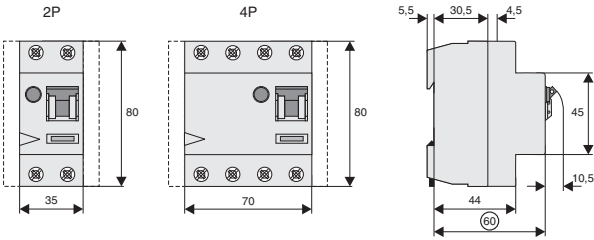

Correct connection

2-pole

30, 100, 300, 500mA types:

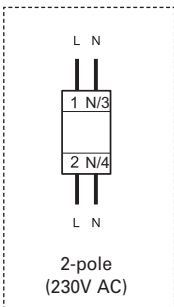

4-pole

30mA types:

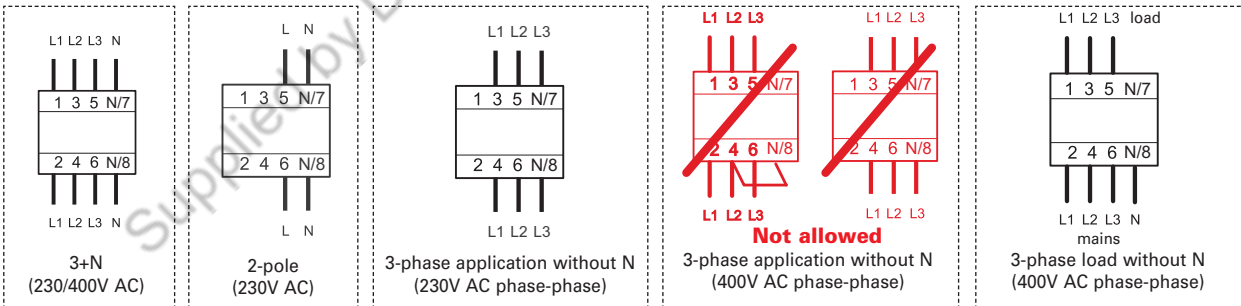

10, 100, 300, 500mA types:

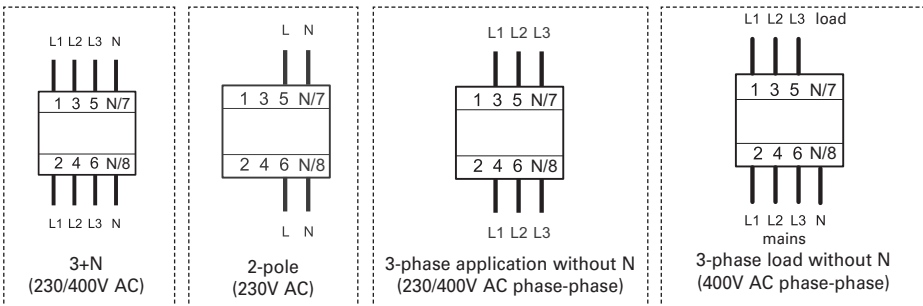

Influence of the ambient temperature to the maximum continuous current (A)

Ambient temperature	16A		25A		40A		63A		80A		100A	
	2p	4p	2p	4p	2p	4p	2p	4p	2p	4p	2p	4p
40°	16	16	25	25	40	40	63	63	80	80	100	100
45°	14	14	21	22	37	37	59	59	76	76	95	95
50°	11	11	18	19	33	34	55	55	72	72	90	90
55°	9	9	14	16	30	31	50	50	68	68	85	85
60°	- *)	-	-	-	26	27	45	45	64	64	80	80

Annotation: It has to be ensured that the values in the table are not exceeded and the back-up fuse/thermal protection works properly.

*) not applicable

Supplied by Digital Stout Innovation & Trading FZE UAE

SG66412



Description

- High-quality residual current device / miniature circuit breaker combination, line voltage-independent
- Contact position indicator red - green
- Guide for secure terminal connection
- 3-position DIN rail clip, permits removal from existing busbar system
- Comprehensive range of accessories suitable for subsequent installation
- Wide variety of rated tripping currents
- Rated currents up to 40 A
- Tripping characteristics B, C
- Rated breaking capacity 10 kA

Supplied by Digital Stout Innovation & Trading FZE UAE

$I_n/I_{\Delta n}$ (A)	Type Designation	Article No.	Units per package
---------------------------	---------------------	-------------	----------------------

Type G

10 kA, 1+N-pole
Surge current-proof 3 kA, type G (ÖVE E 8601)

SG66412



Characteristic B

13/0.03	mRBM-13/1N/B/003-G	147374	1 / 60
16/0.03	mRBM-16/1N/B/003-G	147375	1 / 60
20/0.03	mRBM-20/1N/B/003-G	147376	1 / 60
25/0.03	mRBM-25/1N/B/003-G	147377	1 / 60
32/0.03	mRBM-32/1N/B/003-G	147378	1 / 60
40/0.03	mRBM-40/1N/B/003-G	147379	1 / 60

SG66412



Characteristic C

13/0.03	mRBM-13/1N/C/003-G	147380	1 / 60
16/0.03	mRBM-16/1N/C/003-G	147381	1 / 60
20/0.03	mRBM-20/1N/C/003-G	147382	1 / 60
25/0.03	mRBM-25/1N/C/003-G	147383	1 / 60
32/0.03	mRBM-32/1N/C/003-G	147384	1 / 60
40/0.03	mRBM-40/1N/C/003-G	147385	1 / 60

Supplied by Digital Stout Innovation & Trading FZE UAE

$I_n/I_{\Delta n}$ (A)	Type Designation	Article No.	Units per package
---------------------------	---------------------	-------------	----------------------

Type A

10 kA, 1+N-pole
Conditionally surge current-proof 250 A, sensitive to residual pulsating DC, type A

SG66412



Characteristic B

2/0.01	mRBM-2/1N/B/001-A	147302	1 / 60
4/0.01	mRBM-4/1N/B/001-A	147303	1 / 60
6/0.01	mRBM-6/1N/B/001-A	147304	1 / 60
10/0.01	mRBM-10/1N/B/001-A	147305	1 / 60
13/0.01	mRBM-13/1N/B/001-A	147306	1 / 60
16/0.01	mRBM-16/1N/B/001-A	147307	1 / 60
2/0.03	mRBM-2/1N/B/003-A	147308	1 / 60
4/0.03	mRBM-4/1N/B/003-A	147309	1 / 60
6/0.03	mRBM-6/1N/B/003-A	147310	1 / 60
10/0.03	mRBM-10/1N/B/003-A	147311	1 / 60
13/0.03	mRBM-13/1N/B/003-A	147312	1 / 60
16/0.03	mRBM-16/1N/B/003-A	147313	1 / 60
20/0.03	mRBM-20/1N/B/003-A	147314	1 / 60
25/0.03	mRBM-25/1N/B/003-A	147315	1 / 60
32/0.03	mRBM-32/1N/B/003-A	147316	1 / 60
40/0.03	mRBM-40/1N/B/003-A	147317	1 / 60
2/0.1	mRBM-2/1N/B/01-A	147318	1 / 60
4/0.1	mRBM-4/1N/B/01-A	147319	1 / 60
6/0.1	mRBM-6/1N/B/01-A	147320	1 / 60
10/0.1	mRBM-10/1N/B/01-A	147321	1 / 60
13/0.1	mRBM-13/1N/B/01-A	147322	1 / 60
16/0.1	mRBM-16/1N/B/01-A	147323	1 / 60
20/0.1	mRBM-20/1N/B/01-A	147324	1 / 60
25/0.1	mRBM-25/1N/B/01-A	147325	1 / 60
32/0.1	mRBM-32/1N/B/01-A	147326	1 / 60
40/0.1	mRBM-40/1N/B/01-A	147327	1 / 60
2/0.3	mRBM-2/1N/B/03-A	147328	1 / 60
4/0.3	mRBM-4/1N/B/03-A	147329	1 / 60
6/0.3	mRBM-6/1N/B/03-A	147330	1 / 60
10/0.3	mRBM-10/1N/B/03-A	147331	1 / 60
13/0.3	mRBM-13/1N/B/03-A	147332	1 / 60
16/0.3	mRBM-16/1N/B/03-A	147333	1 / 60
20/0.3	mRBM-20/1N/B/03-A	147334	1 / 60
25/0.3	mRBM-25/1N/B/03-A	147335	1 / 60
32/0.3	mRBM-32/1N/B/03-A	147336	1 / 60
40/0.3	mRBM-40/1N/B/03-A	147337	1 / 60

Supplied by Digital Stout Innovations Trading FZE UAE

SG66412



$I_n/I_{\Delta n}$ (A)	Type Designation	Article No.	Units per package
Characteristic C			
2/0.01	mRBM-2/1N/C/001-A	147338	1 / 60
4/0.01	mRBM-4/1N/C/001-A	147339	1 / 60
6/0.01	mRBM-6/1N/C/001-A	147340	1 / 60
10/0.01	mRBM-10/1N/C/001-A	147341	1 / 60
13/0.01	mRBM-13/1N/C/001-A	147342	1 / 60
16/0.01	mRBM-16/1N/C/001-A	147343	1 / 60
2/0.03	mRBM-2/1N/C/003-A	147344	1 / 60
4/0.03	mRBM-4/1N/C/003-A	147345	1 / 60
6/0.03	mRBM-6/1N/C/003-A	147346	1 / 60
10/0.03	mRBM-10/1N/C/003-A	147347	1 / 60
13/0.03	mRBM-13/1N/C/003-A	147348	1 / 60
16/0.03	mRBM-16/1N/C/003-A	147349	1 / 60
20/0.03	mRBM-20/1N/C/003-A	147350	1 / 60
25/0.03	mRBM-25/1N/C/003-A	147351	1 / 60
32/0.03	mRBM-32/1N/C/003-A	147352	1 / 60
40/0.03	mRBM-40/1N/C/003-A	147353	1 / 60
2/0.1	mRBM-2/1N/C/01-A	147354	1 / 60
4/0.1	mRBM-4/1N/C/01-A	147355	1 / 60
6/0.1	mRBM-6/1N/C/01-A	147356	1 / 60
10/0.1	mRBM-10/1N/C/01-A	147357	1 / 60
13/0.1	mRBM-13/1N/C/01-A	147358	1 / 60
16/0.1	mRBM-16/1N/C/01-A	147359	1 / 60
20/0.1	mRBM-20/1N/C/01-A	147360	1 / 60
25/0.1	mRBM-25/1N/C/01-A	147361	1 / 60
32/0.1	mRBM-32/1N/C/01-A	147362	1 / 60
40/0.1	mRBM-40/1N/C/01-A	147363	1 / 60
2/0.3	mRBM-2/1N/C/03-A	147364	1 / 60
4/0.3	mRBM-4/1N/C/03-A	147365	1 / 60
6/0.3	mRBM-6/1N/C/03-A	147366	1 / 60
10/0.3	mRBM-10/1N/C/03-A	147367	1 / 60
13/0.3	mRBM-13/1N/C/03-A	147368	1 / 60
16/0.3	mRBM-16/1N/C/03-A	147369	1 / 60
20/0.3	mRBM-20/1N/C/03-A	147370	1 / 60
25/0.3	mRBM-25/1N/C/03-A	147371	1 / 60
32/0.3	mRBM-32/1N/C/03-A	147372	1 / 60
40/0.3	mRBM-40/1N/C/03-A	147373	1 / 60

Supplied by Digital Stout Innovations (Singapore) Pte Ltd

$I_n/I_{\Delta n}$ (A)	Type Designation	Article No.	Units per package
---------------------------	---------------------	-------------	----------------------

Type AC

10 kA, 1+N-pole
Conditionally surge current-proof 250 A, type AC

SG66412



Characteristic B

2/0.01	mRBM-2/1N/B/001	147230	1 / 60
4/0.01	mRBM-4/1N/B/001	147231	1 / 60
6/0.01	mRBM-6/1N/B/001	147232	1 / 60
10/0.01	mRBM-10/1N/B/001	147233	1 / 60
13/0.01	mRBM-13/1N/B/001	147234	1 / 60
16/0.01	mRBM-16/1N/B/001	147235	1 / 60
2/0.03	mRBM-2/1N/B/003	147236	1 / 60
4/0.03	mRBM-4/1N/B/003	147237	1 / 60
6/0.03	mRBM-6/1N/B/003	147238	1 / 60
10/0.03	mRBM-10/1N/B/003	147239	1 / 60
13/0.03	mRBM-13/1N/B/003	147240	1 / 60
16/0.03	mRBM-16/1N/B/003	147241	1 / 60
20/0.03	mRBM-20/1N/B/003	147242	1 / 60
25/0.03	mRBM-25/1N/B/003	147243	1 / 60
32/0.03	mRBM-32/1N/B/003	147244	1 / 60
40/0.03	mRBM-40/1N/B/003	147245	1 / 60
2/0.1	mRBM-2/1N/B/01	147246	1 / 60
4/0.1	mRBM-4/1N/B/01	147247	1 / 60
6/0.1	mRBM-6/1N/B/01	147248	1 / 60
10/0.1	mRBM-10/1N/B/01	147249	1 / 60
13/0.1	mRBM-13/1N/B/01	147250	1 / 60
16/0.1	mRBM-16/1N/B/01	147251	1 / 60
20/0.1	mRBM-20/1N/B/01	147252	1 / 60
25/0.1	mRBM-25/1N/B/01	147253	1 / 60
32/0.1	mRBM-32/1N/B/01	147254	1 / 60
40/0.1	mRBM-40/1N/B/01	147255	1 / 60
2/0.3	mRBM-2/1N/B/03	147256	1 / 60
4/0.3	mRBM-4/1N/B/03	147257	1 / 60
6/0.3	mRBM-6/1N/B/03	147258	1 / 60
10/0.3	mRBM-10/1N/B/03	147259	1 / 60
13/0.3	mRBM-13/1N/B/03	147260	1 / 60
16/0.3	mRBM-16/1N/B/03	147261	1 / 60
20/0.3	mRBM-20/1N/B/03	147262	1 / 60
25/0.3	mRBM-25/1N/B/03	147263	1 / 60
32/0.3	mRBM-32/1N/B/03	147264	1 / 60
40/0.3	mRBM-40/1N/B/03	147265	1 / 60

Supplied by Digital Stout Innovations Trading FZE UAE

SG66412



$I_n/I_{\Delta n}$ (A)	Type Designation	Article No.	Units per package
Characteristic C			
2/0.01	mRBM-2/1N/C/001	147266	1 / 60
4/0.01	mRBM-4/1N/C/001	147267	1 / 60
6/0.01	mRBM-6/1N/C/001	147268	1 / 60
10/0.01	mRBM-10/1N/C/001	147269	1 / 60
13/0.01	mRBM-13/1N/C/001	147270	1 / 60
16/0.01	mRBM-16/1N/C/001	147271	1 / 60
2/0.03	mRBM-2/1N/C/003	147272	1 / 60
4/0.03	mRBM-4/1N/C/003	147273	1 / 60
6/0.03	mRBM-6/1N/C/003	147274	1 / 60
10/0.03	mRBM-10/1N/C/003	147275	1 / 60
13/0.03	mRBM-13/1N/C/003	147276	1 / 60
16/0.03	mRBM-16/1N/C/003	147277	1 / 60
20/0.03	mRBM-20/1N/C/003	147278	1 / 60
25/0.03	mRBM-25/1N/C/003	147279	1 / 60
32/0.03	mRBM-32/1N/C/003	147280	1 / 60
40/0.03	mRBM-40/1N/C/003	147281	1 / 60
2/0.1	mRBM-2/1N/C/01	147282	1 / 60
4/0.1	mRBM-4/1N/C/01	147283	1 / 60
6/0.1	mRBM-6/1N/C/01	147284	1 / 60
10/0.1	mRBM-10/1N/C/01	147285	1 / 60
13/0.1	mRBM-13/1N/C/01	147286	1 / 60
16/0.1	mRBM-16/1N/C/01	147287	1 / 60
20/0.1	mRBM-20/1N/C/01	147288	1 / 60
25/0.1	mRBM-25/1N/C/01	147289	1 / 60
32/0.1	mRBM-32/1N/C/01	147290	1 / 60
40/0.1	mRBM-40/1N/C/01	147291	1 / 60
2/0.3	mRBM-2/1N/C/03	147292	1 / 60
4/0.3	mRBM-4/1N/C/03	147293	1 / 60
6/0.3	mRBM-6/1N/C/03	147294	1 / 60
10/0.3	mRBM-10/1N/C/03	147295	1 / 60
13/0.3	mRBM-13/1N/C/03	147296	1 / 60
16/0.3	mRBM-16/1N/C/03	147297	1 / 60
20/0.3	mRBM-20/1N/C/03	147298	1 / 60
25/0.3	mRBM-25/1N/C/03	147299	1 / 60
32/0.3	mRBM-32/1N/C/03	147300	1 / 60
40/0.3	mRBM-40/1N/C/03	147301	1 / 60

Description	Type Designation	Article No.	Units per package
-------------	---------------------	-------------	----------------------

Terminal covers ASTCVRCCB for RCCB's type mRCM

SG01411



Terminal cover 2MU	ASTCVRCCB2		1
Terminal cover 4MU	ASTCVRCCB4		1

Specifications | Combined RCD/MCB Devices mRBM, 1+N-pole

Description

- Combined RCD/MCB Devices
- Line voltage-independent tripping
- Compatible with standard busbar
- Twin-purpose terminal (lift/open-mouthed) above and below
- Busbar positioning optionally above or below
- Free terminal space despite installed busbar
- Guide for secure terminal connection
- Switching toggle (MCB component) in colour designating the rated current
- Contact position indicator red - green
- Comprehensive range of accessories can be mounted subsequently
- The test key "T" must be pressed every 6 month. The system operator must be informed of this obligation and his responsibility in a way that can be proven (self-adhesive RCD-label enclosed). The test interval of 6 month is valid for residential and similar applications. Under all other conditions (e.g. damply or dusty environments), it's recommended to test in shorter intervals (e.g. monthly).
- Pressing the test key "T" serves the only purpose of function testing the residual current device (RCD). This test does not make earthing resistance measurement (R_E), or proper checking of the earth conductor condition redundant, which must be performed separately.
- **Type -A:** Protects against special forms of residual pulsating DC which have not been smoothed
- **Type -G:** 10 ms time delay in order to avoid unwanted tripping (e.g. during thunderstorms).
Compulsory in Austria for any circuit where personal injury or damage to property may occur in case of unwanted tripping (§12.1.6 ÖVE/ÖNORM E 8001-1).

Accessories:

Auxiliary switch for subsequent installation	ZP-IHK	286052
	ZP-WHK	286053
Tripping signal switch for subsequent installation	ZP-NHK	248437
Shunt trip release	ZP-ASA/..	248438, 248439
Terminal cover cap	KLV-TC-2	276240
Additional terminal 35 mm ²	Z-HA-EK/35	263960

Supplied by Digital Stout Innovation & Trading FZE UAE

Technical Data

		mRBM, 1+N-pole
Electrical		
Design according to		IEC/EN 61009
Current test marks as printed onto the device		
Line voltage-independent tripping		instantaneous 250 A (8/20 μs), surge current proof
Type G		10 ms delay 3 kA (8/20 μs), surge current proof
Rated voltage	U_e	230 V AC, 50 Hz
Operational voltage range		196-253 V
Rated tripping current	$I_{\Delta n}$	10, 30, 100, 300 mA
Rated non-tripping current	$I_{\Delta no}$	0.5 $I_{\Delta n}$
Rated insulation voltage	U_i	440 VAC
Sensitivity		AC and pulsating DC
Selectivity class		3
Rated breaking capacity	I_{cn}	10 kA
Rated current		2 - 40 A
Rated impulse withstand voltage	U_{imp}	4 kV (1.2/50 μs)
Characteristic		B, C
Maximum back-up fuse (short circuit)		100 A gL (>10 kA)
Endurance		
electrical components		≥ 4,000 switching operations
mechanical components		≥ 20,000 switching operations
Mechanical		
Frame size		45 mm
Device height		80 mm
Device width		35 mm (2MU)
Mounting		3-position DIN rail clip, permits removal from existing busbar system
Degree of protection, switch		IP20
Degree of protection, built-in		IP40
Upper and lower terminals		open mouthed/lift terminals
Terminal protection		finger and hand touch safe, DGUV VS3, EN 50274
Terminal capacity		1 - 25 mm ²
Terminal torque		2 - 2.4 Nm
Busbar thickness		0.8 - 2 mm
Tripping temperature		-25°C to +40°C
Storage- and transport temperature		-35°C to +60°C
Resistance to climatic conditions		according to IEC/EN 61009

Connection diagram

1+N-pole

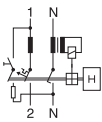

Dimensions (mm)

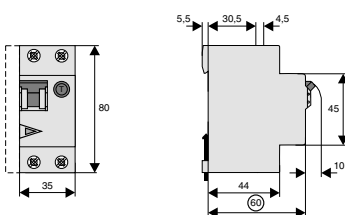

Load Capacity mRBM-../1N/

Effect of ambient temperature (MCB component)

I _n [A]	Ambient temperature T [°C]								
	-25	-20	-10	0	10	20	30	35	40
2	2.5	2.4	2.3	2.2	2.2	2.1	2.0	2.0	1.9
4	4.9	4.8	4.7	4.5	4.3	4.2	4.0	3.9	3.9
5	6.2	6.0	5.8	5.6	5.4	5.2	5.0	4.9	4.8
6	7.4	7.2	7.0	6.7	6.5	6.3	6.0	5.9	5.8
8	9.9	9.6	9.3	9.0	8.7	8.4	8.0	7.9	7.7
10	12	12	12	11	11	10	10	9.9	9.7
12	15	14	14	13	13	13	12	12	12
13	16	16	15	15	14	14	13	13	13
15	19	18	17	17	16	16	15	15	15
16	20	19	19	18	17	17	16	16	15
20	25	24	23	22	22	21	20	20	19
25	31	30	29	28	27	26	25	25	24
32	40	38	37	36	35	33	32	32	31
40	49	48	47	45	43	42	40	39	39

Tripping Characteristic mRBM-../1N/, Characteristics B and C

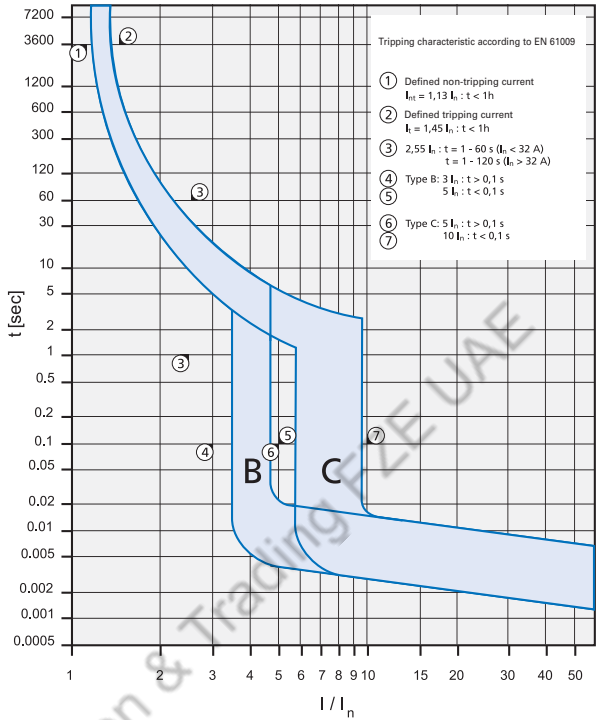

Short Circuit Selectivity mRBM-../1N/ towards DII-DIV fuse link

In case of short circuit, there is selectivity between the combined RCD/MCB devices mRBM-../1N/ and the upstream fuses up to the specified values of the selectivity limit current I_s [kA] (i. e. in case of short-circuit currents I_{ks} under I_s, only the MCB will trip, in case of short circuit currents above this value both protective devices will respond).

*) basically in accordance with EN 60898-1 D.5.2.b

Short circuit selectivity **Characteristic B** towards fuse link **DII-DIV***

mRBM I _n [A]	DII-DIV gL/gG									
	10	16	20	25	35	50	63	80	100	
2	<0.5 ¹⁾	<0.5 ¹⁾	2.2	8.5	10.0 ²⁾	10.0 ²⁾	10.0 ²⁾	10.0 ²⁾	10.0 ²⁾	
4	<0.5 ¹⁾	<0.5 ¹⁾	0.7	1.2	3.7	10.0	10.0 ²⁾	10.0 ²⁾	10.0 ²⁾	
6		<0.5 ¹⁾	0.7	1.0	2.9	6.9	10.0 ²⁾	10.0 ²⁾	10.0 ²⁾	
8		<0.5 ¹⁾	0.6	1.0	2.4	5.1	10.0 ²⁾	10.0 ²⁾	10.0 ²⁾	
10			0.6	0.9	1.9	3.3	7.0	10.0 ²⁾	10.0 ²⁾	
13			0.5	0.7	1.6	2.8	5.7	9.0	10.0 ²⁾	
16				0.7	1.4	2.4	4.4	7.0	10.0 ²⁾	
20					1.3	2.2	4.0	6.3	10.0 ²⁾	
25						1.3	2.1	3.8	5.8	10.0 ²⁾
32							2.0	3.5	5.2	9.5
40								3.1	4.5	8.1

Short circuit selectivity **Characteristic C** towards fuse link **DII-DIV***

mRBM I _n [A]	DII-DIV gL/gG										
	10	16	20	25	35	50	63	80	100		
2	<0.5 ¹⁾	<0.5 ¹⁾	1.7	6.0	10.0 ²⁾	10.0 ²⁾	10.0 ²⁾	10.0 ²⁾	10.0 ²⁾		
4	<0.5 ¹⁾	<0.5 ¹⁾	0.7	1.3	4.2	8.5	10.0 ²⁾	10.0 ²⁾	10.0 ²⁾		
5	<0.5 ¹⁾	<0.5 ¹⁾	0.6	1.1	3.6	7.0	10.0 ²⁾	10.0 ²⁾	10.0 ²⁾		
6		<0.5 ¹⁾	0.6	1.0	2.9	5.8	10.0 ²⁾	10.0 ²⁾	10.0 ²⁾		
8		<0.5 ¹⁾	<0.5	0.9	2.5	4.8	10.0 ²⁾	10.0 ²⁾	10.0 ²⁾		
10			<0.5	0.7	1.5	2.6	5.3	9.0	10.0 ²⁾		
13					1.4	2.3	4.6	7.6	10.0 ²⁾		
16						1.2	1.8	3.4	5.5	10.0 ²⁾	
20							1.2	1.7	3.1	5.0	10.0 ²⁾
25								1.6	2.9	4.6	10.0 ²⁾
32									2.3	3.4	7.7
40										2.9	6.2

¹⁾ Selectivity limit current I_s under 0.5 kA.

²⁾ Selectivity limit current I_s = rated breaking capacity I_{cn} of the RCD/MCB device
Darker areas: no selectivity

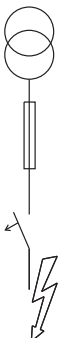

Short Circuit Selectivity mRBM-./1N/ towards D01-D03 fuse link

In case of short circuit, there is selectivity between the combined RCD/MCB devices mRBM-./1N/ and the upstream fuses up to the specified values of the selectivity limit current I_s [kA] (i. e. in case of short-circuit currents I_{ks} under I_s , only the MCB will trip, in case of short circuit currents above this value both protective devices will respond).

*) basically in accordance with EN 60898-1 D.5.2.b

Short circuit selectivity **Characteristic B** towards fuse link **D01-D03***

mRBM	D01-D03 gL/gG									
I_n [A]	10	16	20	25	35	50	63	80	100	
2	<0.5 ¹⁾	0.7	1.6	3.3	10.0 ²⁾	10.0 ²⁾	10.0 ²⁾	10.0 ²⁾	10.0 ²⁾	
4	<0.5 ¹⁾	<0.5 ¹⁾	0.6	0.9	2.9	10.0	10.0 ²⁾	10.0 ²⁾	10.0 ²⁾	
6		<0.5 ¹⁾	0.5	0.8	2.4	8.2	10.0 ²⁾	10.0 ²⁾	10.0 ²⁾	
8			0.6	0.8	2.0	6.0	10.0 ²⁾	10.0 ²⁾	10.0 ²⁾	
10			0.5	0.8	1.6	3.7	6.0	10.0 ²⁾	10.0 ²⁾	
13			0.6	0.7	1.4	3.0	4.7	9.0	10.0 ²⁾	
16				0.6	1.2	2.6	3.9	7.0	10.0 ²⁾	
20					1.2	2.5	3.6	6.2	10.0 ²⁾	
25					1.2	2.3	3.3	5.7	10.0 ²⁾	
32						2.3	3.1	5.1	10.0 ²⁾	
40							2.8	4.5	9.5	

Short circuit selectivity **Characteristic C** towards fuse link **D01-D03***

mRBM	D01-D03 gL/gG									
I_n [A]	10	16	20	25	35	50	63	80	100	
2	<0.5 ¹⁾	0.5	0.5	2.4	10.0 ²⁾	10.0 ²⁾	10.0 ²⁾	10.0 ²⁾	10.0 ²⁾	
4	<0.5 ¹⁾	<0.5 ¹⁾	<0.5 ¹⁾	0.9	3.4	9.5	10.0 ²⁾	10.0 ²⁾	10.0 ²⁾	
5	<0.5 ¹⁾	<0.5 ¹⁾	<0.5 ¹⁾	0.9	2.9	8.0	10.0 ²⁾	10.0 ²⁾	10.0 ²⁾	
6		<0.5 ¹⁾	<0.5 ¹⁾	0.8	2.3	6.5	10.0 ²⁾	10.0 ²⁾	10.0 ²⁾	
8			<0.5 ¹⁾	0.7	2.1	5.5	9.5	10.0 ²⁾	10.0 ²⁾	
10			<0.5 ¹⁾	0.6	1.3	2.9	4.5	8.9	10.0 ²⁾	
13					1.2	2.5	3.9	7.6	10.0 ²⁾	
16					1.0	2.1	3.0	5.5	10.0 ²⁾	
20					1.0	2.0	2.7	5.0	10.0 ²⁾	
25						1.9	2.6	4.5	10.0 ²⁾	
32							2.1	3.4	10.0 ²⁾	
40								3.0	8.7	

Short Circuit Selectivity mRBM-./1N/ towards NH-00 fuse link

In case of short circuit, there is selectivity between the combined RCD/MCB devices mRBM-./1N/ and the upstream fuses up to the specified values of the selectivity limit current I_s [kA] (i. e. in case of short-circuit currents I_{ks} under I_s , only the MCB will trip, in case of short circuit currents above this value both protective devices will respond).

*) basically in accordance with EN 60898-1 D.5.2.b

Short circuit selectivity **Characteristic B** towards fuse link **NH-00***

mRBM	D01-D03 gL/gG												
I_n [A]	16	20	25	32	35	40	50	63	80	100	125	160	
2	<0.5 ¹⁾	1.1	3.6	10.0 ²⁾	10.0 ²⁾	10.0 ²⁾	10.0 ²⁾	10.0 ²⁾	10.0 ²⁾	10.0 ²⁾	10.0 ²⁾	10.0 ²⁾	
4	<0.5 ¹⁾	0.5	0.9	1.6	2.8	4.4	10.0 ²⁾	10.0 ²⁾	10.0 ²⁾	10.0 ²⁾	10.0 ²⁾	10.0 ²⁾	
6	<0.5 ¹⁾	0.5	0.8	1.4	2.2	3.3	7.0	10.0 ²⁾	10.0 ²⁾	10.0 ²⁾	10.0 ²⁾	10.0 ²⁾	
8	<0.5 ¹⁾	<0.5 ¹⁾	0.7	1.0	1.9	2.8	5.3	7.8	10.0 ²⁾	10.0 ²⁾	10.0 ²⁾	10.0 ²⁾	
10		<0.5 ¹⁾	0.7	0.9	1.5	2.1	3.4	4.3	7.3	10.0 ²⁾	10.0 ²⁾	10.0 ²⁾	
13		<0.5 ¹⁾	0.6	0.8	1.4	1.8	2.8	3.6	5.7	10.0 ²⁾	10.0 ²⁾	10.0 ²⁾	
16			0.6	0.7	1.2	1.5	2.4	3.0	4.5	10.0 ²⁾	10.0 ²⁾	10.0 ²⁾	
20				0.7	1.1	1.5	2.2	2.8	4.2	9.2	10.0 ²⁾	10.0 ²⁾	
25					0.7	1.1	1.4	2.1	2.6	4.0	8.2	10.0 ²⁾	10.0 ²⁾
32						1.0	1.4	2.0	2.5	3.7	7.1	10.0 ²⁾	10.0 ²⁾
40								2.3	3.4	6.2	8.8	10.0 ²⁾	

Short circuit selectivity **Characteristic C** towards fuse link **NH-00***

mRBM	D01-D03 gL/gG												
I_n [A]	16	20	25	32	35	40	50	63	80	100	125	160	
2	<0.5 ¹⁾	0.6	2.6	10.0 ²⁾	10.0 ²⁾	10.0 ²⁾	10.0 ²⁾	10.0 ²⁾	10.0 ²⁾	10.0 ²⁾	10.0 ²⁾	10.0 ²⁾	
4	<0.5 ¹⁾	<0.5 ¹⁾	0.9	1.8	3.2	4.8	8.7	10.0 ²⁾	10.0 ²⁾	10.0 ²⁾	10.0 ²⁾	10.0 ²⁾	
5	<0.5 ¹⁾	<0.5 ¹⁾	0.8	1.6	2.7	4.1	7.2	9.7	10.0 ²⁾	10.0 ²⁾	10.0 ²⁾	10.0 ²⁾	
6	<0.5 ¹⁾	<0.5 ¹⁾	0.7	1.3	2.2	3.3	5.9	8.0	10.0 ²⁾	10.0 ²⁾	10.0 ²⁾	10.0 ²⁾	
8	<0.5 ¹⁾	<0.5 ¹⁾	0.6	1.1	1.9	2.8	5.0	6.7	10.0 ²⁾	10.0 ²⁾	10.0 ²⁾	10.0 ²⁾	
10			0.5	0.8	1.2	1.7	2.7	3.4	5.5	10.0 ²⁾	10.0 ²⁾	10.0 ²⁾	
13					1.1	1.5	2.3	2.9	4.7	10.0 ²⁾	10.0 ²⁾	10.0 ²⁾	
16					1.0	1.3	1.8	2.3	3.7	8.7	10.0 ²⁾	10.0 ²⁾	
20						0.9	1.1	1.7	2.2	3.4	8.0	10.0 ²⁾	10.0 ²⁾
25							1.6	2.1	3.2	7.2	10.0 ²⁾	10.0 ²⁾	
32								1.7	2.6	5.3	9.0	10.0 ²⁾	
40									2.4	4.5	7.5	10.0	

¹⁾ Selectivity limit current I_s under 0.5 kA.

²⁾ Selectivity limit current I_s = rated breaking capacity I_{cn} of the RCD/MCB device
Darker areas: no selectivity



Let-through Energy mRBM-../1N/

Let-through Energy mRBM, Characteristic B, 1+N-pole

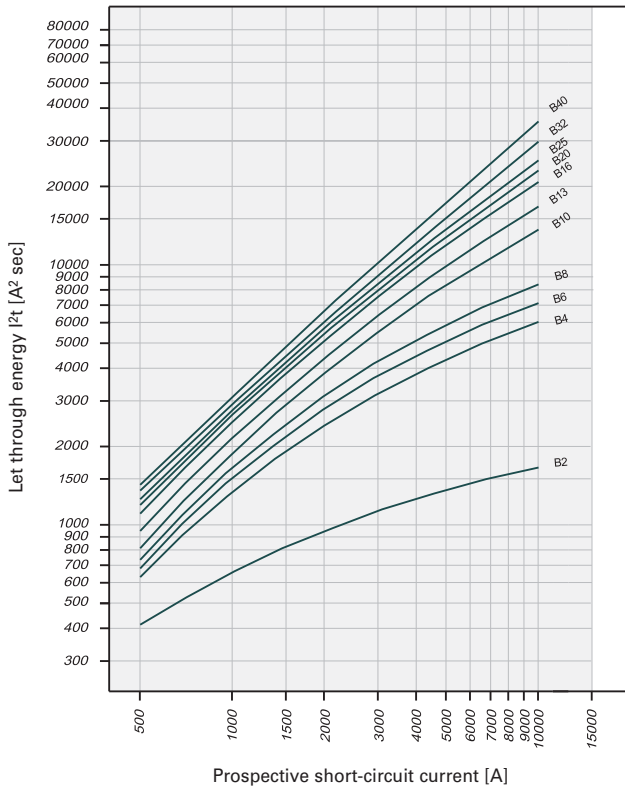

Let-through Energy mRBM, Characteristic C, 1+N-pole

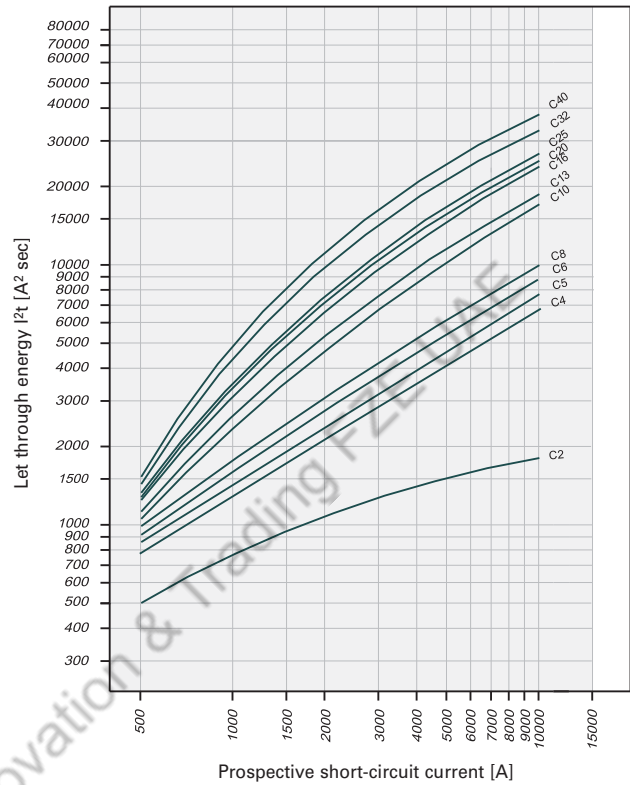

Supplied by Digital Stout Innovation & Trading FZLLP

SG66512



Description

- Contact position indicator red - green
- Guide for secure terminal connection
- 3-position DIN rail clip, permits removal from existing busbar system
- Comprehensive range of accessories suitable for subsequent installation
- Rated currents up to 63 A
- Tripping characteristics B, C, D
- Rated breaking capacity according to IEC/EN

60898-1

mMCM: 10 kA

mMC6: 6 kA

mMC4: 4.5 kA

Supplied by Digital Stout Innovation & Trading FZE UAE

SG65412



Rated current
 I_n (A)

Type
Designation

Article No. Units per package

10 kA, Characteristic B

1-pole

1	mMCM-B1/1	138858	12/120
2	mMCM-B2/1	138859	12/120
3	mMCM-B3/1	138860	12/120
4	mMCM-B4/1	138861	12/120
5	mMCM-B5/1	170041	12/120
6	mMCM-B6/1	138862	12/120
8	mMCM-B8/1	170042	12/120
10	mMCM-B10/1	138863	12/120
12	mMCM-B12/1	170043	12/120
13	mMCM-B13/1	138864	12/120
15	mMCM-B15/1	170044	12/120
16	mMCM-B16/1	138865	12/120
20	mMCM-B20/1	138866	12/120
25	mMCM-B25/1	138867	12/120
32	mMCM-B32/1	138868	12/120
40	mMCM-B40/1	138869	12/120
50	mMCM-B50/1	138870	12/120
63	mMCM-B63/1	138871	12/120

SG66112



1+N-pole, 2 Module Units (MU)

1	mMCM-B1/1N	139338	1/60
2	mMCM-B2/1N	139339	1/60
3	mMCM-B3/1N	139340	1/60
4	mMCM-B4/1N	139341	1/60
5	mMCM-B5/1N	170045	1/60
6	mMCM-B6/1N	139342	1/60
8	mMCM-B8/1N	170046	1/60
10	mMCM-B10/1N	139343	1/60
12	mMCM-B12/1N	170047	1/60
13	mMCM-B13/1N	139344	1/60
15	mMCM-B15/1N	170048	1/60
16	mMCM-B16/1N	139345	1/60
20	mMCM-B20/1N	139346	1/60
25	mMCM-B25/1N	139347	1/60
32	mMCM-B32/1N	139348	1/60
40	mMCM-B40/1N	139349	1/60
50	mMCM-B50/1N	139350	1/60
63	mMCM-B63/1N	139351	1/60

SG66212



2-pole

1	mMCM-B1/2	138978	1/60
2	mMCM-B2/2	138979	1/60
3	mMCM-B3/2	138980	1/60
4	mMCM-B4/2	138981	1/60
5	mMCM-B5/2	170049	1/60
6	mMCM-B6/2	138982	1/60
8	mMCM-B8/2	170050	1/60
10	mMCM-B10/2	138983	1/60
12	mMCM-B12/2	170051	1/60
13	mMCM-B13/2	138984	1/60
15	mMCM-B15/2	170052	1/60
16	mMCM-B16/2	138985	1/60
20	mMCM-B20/2	138986	1/60
25	mMCM-B25/2	138987	1/60
32	mMCM-B32/2	138988	1/60
40	mMCM-B40/2	138989	1/60
50	mMCM-B50/2	138990	1/60
63	mMCM-B63/2	138991	1/60

Miniature Circuit Breakers mMCM

SG66512



Rated current I_n (A)	Type Designation	Article No.	Units per package
3-pole			
1	mMCM-B1/3	139098	1/40
2	mMCM-B2/3	139099	1/40
3	mMCM-B3/3	139100	1/40
4	mMCM-B4/3	139101	1/40
5	mMCM-B5/3	170053	1/40
6	mMCM-B6/3	139102	1/40
8	mMCM-B8/3	170054	1/40
10	mMCM-B10/3	139103	1/40
12	mMCM-B12/3	170055	1/40
13	mMCM-B13/3	139104	1/40
15	mMCM-B15/3	170056	1/40
16	mMCM-B16/3	139105	1/40
20	mMCM-B20/3	139106	1/40
25	mMCM-B25/3	139107	1/40
32	mMCM-B32/3	139108	1/40
40	mMCM-B40/3	139109	1/40
50	mMCM-B50/3	139110	1/40
63	mMCM-B63/3	139111	1/40

SG67012



Rated current I_n (A)	Type Designation	Article No.	Units per package
3+N-pole			
1	mMCM-B1/3N	139458	1/30
2	mMCM-B2/3N	139459	1/30
3	mMCM-B3/3N	139460	1/30
4	mMCM-B4/3N	139461	1/30
5	mMCM-B5/3N	170057	1/30
6	mMCM-B6/3N	139462	1/30
8	mMCM-B8/3N	170058	1/30
10	mMCM-B10/3N	139463	1/30
12	mMCM-B12/3N	170059	1/30
13	mMCM-B13/3N	139464	1/30
15	mMCM-B15/3N	170060	1/30
16	mMCM-B16/3N	139465	1/30
20	mMCM-B20/3N	139466	1/30
25	mMCM-B25/3N	139467	1/30
32	mMCM-B32/3N	139468	1/30
40	mMCM-B40/3N	139469	1/30
50	mMCM-B50/3N	139470	1/30
63	mMCM-B63/3N	139471	1/30

SG66912



Rated current I_n (A)	Type Designation	Article No.	Units per package
4-pole			
1	mMCM-B1/4	139218	1/30
2	mMCM-B2/4	139219	1/30
3	mMCM-B3/4	139220	1/30
4	mMCM-B4/4	139221	1/30
5	mMCM-B5/4	170061	1/30
6	mMCM-B6/4	139222	1/30
8	mMCM-B8/4	170062	1/30
10	mMCM-B10/4	139223	1/30
12	mMCM-B12/4	170063	1/30
13	mMCM-B13/4	139224	1/30
15	mMCM-B15/4	170064	1/30
16	mMCM-B16/4	139225	1/30
20	mMCM-B20/4	139226	1/30
25	mMCM-B25/4	139227	1/30
32	mMCM-B32/4	139228	1/30
40	mMCM-B40/4	139229	1/30
50	mMCM-B50/4	139230	1/30
63	mMCM-B63/4	139231	1/30

Rated current I_n (A)	Type Designation	Article No.	Units per package
----------------------------	---------------------	-------------	----------------------

10 kA, Characteristic C

SG65412



1-pole

1	mMCM-C1/1	138872	12/120
2	mMCM-C2/1	138873	12/120
3	mMCM-C3/1	138874	12/120
4	mMCM-C4/1	138875	12/120
5	mMCM-C5/1	170065	12/120
6	mMCM-C6/1	138876	12/120
8	mMCM-C8/1	170066	12/120
10	mMCM-C10/1	138877	12/120
12	mMCM-C12/1	170067	12/120
13	mMCM-C13/1	138878	12/120
15	mMCM-C15/1	170068	12/120
16	mMCM-C16/1	138879	12/120
20	mMCM-C20/1	138880	12/120
25	mMCM-C25/1	138881	12/120
32	mMCM-C32/1	138882	12/120
40	mMCM-C40/1	138883	12/120
50	mMCM-C50/1	138884	12/120
63	mMCM-C63/1	138885	12/120

SG66112



1+N-pole, 2 Module Units (MU)

1	mMCM-C1/1N	139352	1/60
2	mMCM-C2/1N	139353	1/60
3	mMCM-C3/1N	139354	1/60
4	mMCM-C4/1N	139355	1/60
5	mMCM-C5/1N	170069	1/60
6	mMCM-C6/1N	139356	1/60
8	mMCM-C8/1N	170070	1/60
10	mMCM-C10/1N	139357	1/60
12	mMCM-C12/1N	170071	1/60
13	mMCM-C13/1N	139358	1/60
15	mMCM-C15/1N	170072	1/60
16	mMCM-C16/1N	139359	1/60
20	mMCM-C20/1N	139360	1/60
25	mMCM-C25/1N	139361	1/60
32	mMCM-C32/1N	139362	1/60
40	mMCM-C40/1N	139363	1/60
50	mMCM-C50/1N	139364	1/60
63	mMCM-C63/1N	139365	1/60

SG66212



2-pole

1	mMCM-C1/2	138992	1/60
2	mMCM-C2/2	138993	1/60
3	mMCM-C3/2	138994	1/60
4	mMCM-C4/2	138995	1/60
5	mMCM-C5/2	170073	1/60
6	mMCM-C6/2	138996	1/60
8	mMCM-C8/2	170074	1/60
10	mMCM-C10/2	138997	1/60
12	mMCM-C12/2	170075	1/60
13	mMCM-C13/2	138998	1/60
15	mMCM-C15/2	170076	1/60
16	mMCM-C16/2	138999	1/60
20	mMCM-C20/2	139000	1/60
25	mMCM-C25/2	139001	1/60
32	mMCM-C32/2	139002	1/60
40	mMCM-C40/2	139003	1/60
50	mMCM-C50/2	139004	1/60
63	mMCM-C63/2	139005	1/60

SG66512



Rated current I_n (A)	Type Designation	Article No.	Units per package
3-pole			
1	mMCM-C1/3	139112	1/40
2	mMCM-C2/3	139113	1/40
3	mMCM-C3/3	139114	1/40
4	mMCM-C4/3	139115	1/40
5	mMCM-C5/3	170077	1/40
6	mMCM-C6/3	139116	1/40
8	mMCM-C8/3	170078	1/40
10	mMCM-C10/3	139117	1/40
12	mMCM-C12/3	170079	1/40
13	mMCM-C13/3	139118	1/40
15	mMCM-C15/3	170080	1/40
16	mMCM-C16/3	139119	1/40
20	mMCM-C20/3	139120	1/40
25	mMCM-C25/3	139121	1/40
32	mMCM-C32/3	139122	1/40
40	mMCM-C40/3	139123	1/40
50	mMCM-C50/3	139124	1/40
63	mMCM-C63/3	139125	1/40

SG67012



Rated current I_n (A)	Type Designation	Article No.	Units per package
3+N-pole			
1	mMCM-C1/3N	139472	1/30
2	mMCM-C2/3N	139473	1/30
3	mMCM-C3/3N	139474	1/30
4	mMCM-C4/3N	139475	1/30
5	mMCM-C5/3N	170081	1/30
6	mMCM-C6/3N	139476	1/30
8	mMCM-C8/3N	170082	1/30
10	mMCM-C10/3N	139477	1/30
12	mMCM-C12/3N	170083	1/30
13	mMCM-C13/3N	139478	1/30
15	mMCM-C15/3N	170084	1/30
16	mMCM-C16/3N	139479	1/30
20	mMCM-C20/3N	139480	1/30
25	mMCM-C25/3N	139481	1/30
32	mMCM-C32/3N	139482	1/30
40	mMCM-C40/3N	139483	1/30
50	mMCM-C50/3N	139484	1/30
63	mMCM-C63/3N	139485	1/30

SG66912



Rated current I_n (A)	Type Designation	Article No.	Units per package
4-pole			
1	mMCM-C1/4	139232	1/30
2	mMCM-C2/4	139233	1/30
3	mMCM-C3/4	139234	1/30
4	mMCM-C4/4	139235	1/30
5	mMCM-C5/4	170085	1/30
6	mMCM-C6/4	139236	1/30
8	mMCM-C8/4	170086	1/30
10	mMCM-C10/4	139237	1/30
12	mMCM-C12/4	170087	1/30
13	mMCM-C13/4	139238	1/30
15	mMCM-C15/4	170088	1/30
16	mMCM-C16/4	139239	1/30
20	mMCM-C20/4	139240	1/30
25	mMCM-C25/4	139241	1/30
32	mMCM-C32/4	139242	1/30
40	mMCM-C40/4	139243	1/30
50	mMCM-C50/4	139244	1/30
63	mMCM-C63/4	139245	1/30

Rated current I_n (A)	Type Designation	Article No.	Units per package
----------------------------	---------------------	-------------	----------------------

10 kA, Characteristic D

SG65412



1-pole

1	mMCM-D1/1	138886	12/120
2	mMCM-D2/1	138887	12/120
3	mMCM-D3/1	138888	12/120
4	mMCM-D4/1	138889	12/120
5	mMCM-D5/1	170089	12/120
6	mMCM-D6/1	138890	12/120
8	mMCM-D8/1	170090	12/120
10	mMCM-D10/1	138891	12/120
12	mMCM-D12/1	170091	12/120
13	mMCM-D13/1	138892	12/120
15	mMCM-D15/1	170092	12/120
16	mMCM-D16/1	138893	12/120
20	mMCM-D20/1	138894	12/120
25	mMCM-D25/1	138895	12/120
32	mMCM-D32/1	138896	12/120
40	mMCM-D40/1	138897	12/120

SG66112



1+N-pole, 2 Module Units (MU)

1	mMCM-D1/1N	139366	1/60
2	mMCM-D2/1N	139367	1/60
3	mMCM-D3/1N	139368	1/60
4	mMCM-D4/1N	139369	1/60
5	mMCM-D5/1N	170093	1/60
6	mMCM-D6/1N	139370	1/60
8	mMCM-D8/1N	170094	1/60
10	mMCM-D10/1N	139371	1/60
12	mMCM-D12/1N	170095	1/60
13	mMCM-D13/1N	139372	1/60
15	mMCM-D15/1N	170096	1/60
16	mMCM-D16/1N	139373	1/60
20	mMCM-D20/1N	139374	1/60
25	mMCM-D25/1N	139375	1/60
32	mMCM-D32/1N	139376	1/60
40	mMCM-D40/1N	139377	1/60

SG66212



2-pole

1	mMCM-D1/2	139006	1/60
2	mMCM-D2/2	139007	1/60
3	mMCM-D3/2	139008	1/60
4	mMCM-D4/2	139009	1/60
5	mMCM-D5/2	170097	1/60
6	mMCM-D6/2	139010	1/60
8	mMCM-D8/2	170098	1/60
10	mMCM-D10/2	139011	1/60
12	mMCM-D12/2	169941	1/60
13	mMCM-D13/2	139012	1/60
15	mMCM-D15/2	169942	1/60
16	mMCM-D16/2	139013	1/60
20	mMCM-D20/2	139014	1/60
25	mMCM-D25/2	139015	1/60
32	mMCM-D32/2	139016	1/60
40	mMCM-D40/2	139017	1/60

Miniature Circuit Breakers mMCM

SG66512



Rated current I_n (A)	Type Designation	Article No.	Units per package
3-pole			
1	mMCM-D1/3	139126	1/40
2	mMCM-D2/3	139127	1/40
3	mMCM-D3/3	139128	1/40
4	mMCM-D4/3	139129	1/40
5	mMCM-D5/3	169943	1/40
6	mMCM-D6/3	139130	1/40
8	mMCM-D8/3	169944	1/40
10	mMCM-D10/3	139131	1/40
12	mMCM-D12/3	169945	1/40
13	mMCM-D13/3	139132	1/40
15	mMCM-D15/3	169946	1/40
16	mMCM-D16/3	139133	1/40
20	mMCM-D20/3	139134	1/40
25	mMCM-D25/3	139135	1/40
32	mMCM-D32/3	139136	1/40
40	mMCM-D40/3	139137	1/40

SG67012



Rated current I_n (A)	Type Designation	Article No.	Units per package
3+N-pole			
1	mMCM-D1/3N	139486	1/30
2	mMCM-D2/3N	139487	1/30
3	mMCM-D3/3N	139488	1/30
4	mMCM-D4/3N	139489	1/30
5	mMCM-D5/3N	169947	1/30
6	mMCM-D6/3N	139490	1/30
8	mMCM-D8/3N	169948	1/30
10	mMCM-D10/3N	139491	1/30
12	mMCM-D12/3N	169949	1/30
13	mMCM-D13/3N	139492	1/30
15	mMCM-D15/3N	169950	1/30
16	mMCM-D16/3N	139493	1/30
20	mMCM-D20/3N	139494	1/30
25	mMCM-D25/3N	139495	1/30
32	mMCM-D32/3N	139496	1/30
40	mMCM-D40/3N	139497	1/30

SG66912



Rated current I_n (A)	Type Designation	Article No.	Units per package
4-pole			
1	mMCM-D1/4	139246	1/30
2	mMCM-D2/4	139247	1/30
3	mMCM-D3/4	139248	1/30
4	mMCM-D4/4	139249	1/30
5	mMCM-D5/4	169951	1/30
6	mMCM-D6/4	139250	1/30
8	mMCM-D8/4	169952	1/30
10	mMCM-D10/4	139251	1/30
12	mMCM-D12/4	169953	1/30
13	mMCM-D13/4	139252	1/30
15	mMCM-D15/4	169954	1/30
16	mMCM-D16/4	139253	1/30
20	mMCM-D20/4	139254	1/30
25	mMCM-D25/4	139255	1/30
32	mMCM-D32/4	139256	1/30
40	mMCM-D40/4	139257	1/30

SG65412



Rated current
 I_n (A)

Type
Designation

Article No. Units per package

6 kA, Characteristic B

1-pole

Rated current I_n (A)	Type Designation	Article No.	Units per package
1	mMC6-B1/1	138818	12/120
2	mMC6-B2/1	138819	12/120
3	mMC6-B3/1	138820	12/120
4	mMC6-B4/1	138821	12/120
5	mMC6-B5/1	169969	12/120
6	mMC6-B6/1	138822	12/120
8	mMC6-B8/1	169970	12/120
10	mMC6-B10/1	138823	12/120
12	mMC6-B12/1	169971	12/120
13	mMC6-B13/1	138824	12/120
15	mMC6-B15/1	169972	12/120
16	mMC6-B16/1	138825	12/120
20	mMC6-B20/1	138826	12/120
25	mMC6-B25/1	138827	12/120
32	mMC6-B32/1	138828	12/120
40	mMC6-B40/1	138829	12/120
50	mMC6-B50/1	138830	12/120
63	mMC6-B63/1	138831	12/120

SG66112



1+N-pole, 2 Module Units (MU)

Rated current I_n (A)	Type Designation	Article No.	Units per package
1	mMC6-B1/1N	139298	1/60
2	mMC6-B2/1N	139299	1/60
3	mMC6-B3/1N	139300	1/60
4	mMC6-B4/1N	139301	1/60
5	mMC6-B5/1N	169973	1/60
6	mMC6-B6/1N	139302	1/60
8	mMC6-B8/1N	169974	1/60
10	mMC6-B10/1N	139303	1/60
12	mMC6-B12/1N	169975	1/60
13	mMC6-B13/1N	139304	1/60
15	mMC6-B15/1N	169976	1/60
16	mMC6-B16/1N	139305	1/60
20	mMC6-B20/1N	139306	1/60
25	mMC6-B25/1N	139307	1/60
32	mMC6-B32/1N	139308	1/60
40	mMC6-B40/1N	139309	1/60
50	mMC6-B50/1N	139310	1/60
63	mMC6-B63/1N	139311	1/60

SG66212



2-pole

Rated current I_n (A)	Type Designation	Article No.	Units per package
1	mMC6-B1/2	138938	1/60
2	mMC6-B2/2	138939	1/60
3	mMC6-B3/2	138940	1/60
4	mMC6-B4/2	138941	1/60
5	mMC6-B5/2	169977	1/60
6	mMC6-B6/2	138942	1/60
8	mMC6-B8/2	169978	1/60
10	mMC6-B10/2	138943	1/60
12	mMC6-B12/2	169979	1/60
13	mMC6-B13/2	138944	1/60
15	mMC6-B15/2	169980	1/60
16	mMC6-B16/2	138945	1/60
20	mMC6-B20/2	138946	1/60
25	mMC6-B25/2	138947	1/60
32	mMC6-B32/2	138948	1/60
40	mMC6-B40/2	138949	1/60
50	mMC6-B50/2	138950	1/60
63	mMC6-B63/2	138951	1/60

Miniature Circuit Breakers mMC6

SG66512



Rated current I_n (A)	Type Designation	Article No.	Units per package
3-pole			
1	mMC6-B1/3	139058	1/40
2	mMC6-B2/3	139059	1/40
3	mMC6-B3/3	139060	1/40
4	mMC6-B4/3	139061	1/40
5	mMC6-B5/3	169981	1/40
6	mMC6-B6/3	139062	1/40
8	mMC6-B8/3	169982	1/40
10	mMC6-B10/3	139063	1/40
12	mMC6-B12/3	169983	1/40
13	mMC6-B13/3	139064	1/40
15	mMC6-B15/3	169984	1/40
16	mMC6-B16/3	139065	1/40
20	mMC6-B20/3	139066	1/40
25	mMC6-B25/3	139067	1/40
32	mMC6-B32/3	139068	1/40
40	mMC6-B40/3	139069	1/40
50	mMC6-B50/3	139070	1/40
63	mMC6-B63/3	139071	1/40

SG67012



Rated current I_n (A)	Type Designation	Article No.	Units per package
3+N-pole			
1	mMC6-B1/3N	139418	1/30
2	mMC6-B2/3N	139419	1/30
3	mMC6-B3/3N	139420	1/30
4	mMC6-B4/3N	139421	1/30
5	mMC6-B5/3N	169985	1/30
6	mMC6-B6/3N	139422	1/30
8	mMC6-B8/3N	169986	1/30
10	mMC6-B10/3N	139423	1/30
12	mMC6-B12/3N	169987	1/30
13	mMC6-B13/3N	139424	1/30
15	mMC6-B15/3N	169988	1/30
16	mMC6-B16/3N	139425	1/30
20	mMC6-B20/3N	139426	1/30
25	mMC6-B25/3N	139427	1/30
32	mMC6-B32/3N	139428	1/30
40	mMC6-B40/3N	139429	1/30
50	mMC6-B50/3N	139430	1/30
63	mMC6-B63/3N	139431	1/30

SG66912



Rated current I_n (A)	Type Designation	Article No.	Units per package
4-pole			
1	mMC6-B1/4	139178	1/30
2	mMC6-B2/4	139179	1/30
3	mMC6-B3/4	139180	1/30
4	mMC6-B4/4	139181	1/30
5	mMC6-B5/4	169989	1/30
6	mMC6-B6/4	139182	1/30
8	mMC6-B8/4	169990	1/30
10	mMC6-B10/4	139183	1/30
12	mMC6-B12/4	169991	1/30
13	mMC6-B13/4	139184	1/30
15	mMC6-B15/4	169992	1/30
16	mMC6-B16/4	139185	1/30
20	mMC6-B20/4	139186	1/30
25	mMC6-B25/4	139187	1/30
32	mMC6-B32/4	139188	1/30
40	mMC6-B40/4	139189	1/30
50	mMC6-B50/4	139190	1/30
63	mMC6-B63/4	139191	1/30

Rated current I_n (A)	Type Designation	Article No.	Units per package
----------------------------	---------------------	-------------	----------------------

6 kA, Characteristic C

SG65412



1-pole

0.5	mMC6-C0.5/1	168562	12/120
1	mMC6-C1/1	138832	12/120
2	mMC6-C2/1	138833	12/120
3	mMC6-C3/1	138834	12/120
4	mMC6-C4/1	138835	12/120
5	mMC6-C5/1	169993	12/120
6	mMC6-C6/1	138836	12/120
8	mMC6-C8/1	169994	12/120
10	mMC6-C10/1	138837	12/120
12	mMC6-C12/1	169995	12/120
13	mMC6-C13/1	138838	12/120
15	mMC6-C15/1	169996	12/120
16	mMC6-C16/1	138839	12/120
20	mMC6-C20/1	138840	12/120
25	mMC6-C25/1	138841	12/120
32	mMC6-C32/1	138842	12/120
40	mMC6-C40/1	138843	12/120
50	mMC6-C50/1	138844	12/120
63	mMC6-C63/1	138845	12/120

SG66112



1+N-pole, 2 Module Units (MU)

1	mMC6-C1/1N	139312	1/60
2	mMC6-C2/1N	139313	1/60
3	mMC6-C3/1N	139314	1/60
4	mMC6-C4/1N	139315	1/60
5	mMC6-C5/1N	169997	1/60
6	mMC6-C6/1N	139316	1/60
8	mMC6-C8/1N	169998	1/60
10	mMC6-C10/1N	139317	1/60
12	mMC6-C12/1N	169999	1/60
13	mMC6-C13/1N	139318	1/60
15	mMC6-C15/1N	170000	1/60
16	mMC6-C16/1N	139319	1/60
20	mMC6-C20/1N	139320	1/60
25	mMC6-C25/1N	139321	1/60
32	mMC6-C32/1N	139322	1/60
40	mMC6-C40/1N	139323	1/60
50	mMC6-C50/1N	139324	1/60
63	mMC6-C63/1N	139325	1/60

SG66212



2-pole

0.5	mMC6-C0.5/2	168563	1/60
1	mMC6-C1/2	138952	1/60
2	mMC6-C2/2	138953	1/60
3	mMC6-C3/2	138954	1/60
4	mMC6-C4/2	138955	1/60
5	mMC6-C5/2	170001	1/60
6	mMC6-C6/2	138956	1/60
8	mMC6-C8/2	170002	1/60
10	mMC6-C10/2	138957	1/60
12	mMC6-C12/2	170003	1/60
13	mMC6-C13/2	138958	1/60
15	mMC6-C15/2	170004	1/60
16	mMC6-C16/2	138959	1/60
20	mMC6-C20/2	138960	1/60
25	mMC6-C25/2	138961	1/60
32	mMC6-C32/2	138962	1/60
40	mMC6-C40/2	138963	1/60
50	mMC6-C50/2	138964	1/60
63	mMC6-C63/2	138965	1/60

Miniature Circuit Breakers mMC6

SG66512



Rated current I_n (A)	Type Designation	Article No.	Units per package
3-pole			
1	mMC6-C1/3	139072	1/40
2	mMC6-C2/3	139073	1/40
3	mMC6-C3/3	139074	1/40
4	mMC6-C4/3	139075	1/40
5	mMC6-C5/3	170005	1/40
6	mMC6-C6/3	139076	1/40
8	mMC6-C8/3	170006	1/40
10	mMC6-C10/3	139077	1/40
12	mMC6-C12/3	170007	1/40
13	mMC6-C13/3	139078	1/40
15	mMC6-C15/3	170008	1/40
16	mMC6-C16/3	139079	1/40
20	mMC6-C20/3	139080	1/40
25	mMC6-C25/3	139081	1/40
32	mMC6-C32/3	139082	1/40
40	mMC6-C40/3	139083	1/40
50	mMC6-C50/3	139084	1/40
63	mMC6-C63/3	139085	1/40

SG67012



Rated current I_n (A)	Type Designation	Article No.	Units per package
3+N-pole			
1	mMC6-C1/3N	139432	1/30
2	mMC6-C2/3N	139433	1/30
3	mMC6-C3/3N	139434	1/30
4	mMC6-C4/3N	139435	1/30
5	mMC6-C5/3N	170009	1/30
6	mMC6-C6/3N	139436	1/30
8	mMC6-C8/3N	170010	1/30
10	mMC6-C10/3N	139437	1/30
12	mMC6-C12/3N	170011	1/30
13	mMC6-C13/3N	139438	1/30
15	mMC6-C15/3N	170012	1/30
16	mMC6-C16/3N	139439	1/30
20	mMC6-C20/3N	139440	1/30
25	mMC6-C25/3N	139441	1/30
32	mMC6-C32/3N	139442	1/30
40	mMC6-C40/3N	139443	1/30
50	mMC6-C50/3N	139444	1/30
63	mMC6-C63/3N	139445	1/30

SG66912



Rated current I_n (A)	Type Designation	Article No.	Units per package
4-pole			
1	mMC6-C1/4	139192	1/30
2	mMC6-C2/4	139193	1/30
3	mMC6-C3/4	139194	1/30
4	mMC6-C4/4	139195	1/30
5	mMC6-C5/4	170013	1/30
6	mMC6-C6/4	139196	1/30
8	mMC6-C8/4	170014	1/30
10	mMC6-C10/4	139197	1/30
12	mMC6-C12/4	170015	1/30
13	mMC6-C13/4	139198	1/30
15	mMC6-C15/4	170016	1/30
16	mMC6-C16/4	139199	1/30
20	mMC6-C20/4	139200	1/30
25	mMC6-C25/4	139201	1/30
32	mMC6-C32/4	139202	1/30
40	mMC6-C40/4	139203	1/30
50	mMC6-C50/4	139204	1/30
63	mMC6-C63/4	139205	1/30

Rated current I_n (A)	Type Designation	Article No.	Units per package
----------------------------	---------------------	-------------	----------------------

6 kA, Characteristic D

SG65412



1-pole

1	mMC6-D1/1	138846	12/120
2	mMC6-D2/1	138847	12/120
3	mMC6-D3/1	138848	12/120
4	mMC6-D4/1	138849	12/120
5	mMC6-D5/1	170017	12/120
6	mMC6-D6/1	138850	12/120
8	mMC6-D8/1	170018	12/120
10	mMC6-D10/1	138851	12/120
12	mMC6-D12/1	170019	12/120
13	mMC6-D13/1	138852	12/120
15	mMC6-D15/1	170020	12/120
16	mMC6-D16/1	138853	12/120
20	mMC6-D20/1	138854	12/120
25	mMC6-D25/1	138855	12/120
32	mMC6-D32/1	138856	12/120
40	mMC6-D40/1	138857	12/120

SG66112



1+N-pole, 2 Module Units (MU)

1	mMC6-D1/1N	139326	1/60
2	mMC6-D2/1N	139327	1/60
3	mMC6-D3/1N	139328	1/60
4	mMC6-D4/1N	139329	1/60
5	mMC6-D5/1N	170021	1/60
6	mMC6-D6/1N	139330	1/60
8	mMC6-D8/1N	170022	1/60
10	mMC6-D10/1N	139331	1/60
12	mMC6-D12/1N	170023	1/60
13	mMC6-D13/1N	139332	1/60
15	mMC6-D15/1N	170024	1/60
16	mMC6-D16/1N	139333	1/60
20	mMC6-D20/1N	139334	1/60
25	mMC6-D25/1N	139335	1/60
32	mMC6-D32/1N	139336	1/60
40	mMC6-D40/1N	139337	1/60

SG66212



2-pole

1	mMC6-D1/2	138966	1/60
2	mMC6-D2/2	138967	1/60
3	mMC6-D3/2	138968	1/60
4	mMC6-D4/2	138969	1/60
5	mMC6-D5/2	170025	1/60
6	mMC6-D6/2	138970	1/60
8	mMC6-D8/2	170026	1/60
10	mMC6-D10/2	138971	1/60
12	mMC6-D12/2	170027	1/60
13	mMC6-D13/2	138972	1/60
15	mMC6-D15/2	170028	1/60
16	mMC6-D16/2	138973	1/60
20	mMC6-D20/2	138974	1/60
25	mMC6-D25/2	138975	1/60
32	mMC6-D32/2	138976	1/60
40	mMC6-D40/2	138977	1/60

Miniature Circuit Breakers mMC6

SG66512



Rated current I_n (A)	Type Designation	Article No.	Units per package
3-pole			
1	mMC6-D1/3	139086	1/40
2	mMC6-D2/3	139087	1/40
3	mMC6-D3/3	139088	1/40
4	mMC6-D4/3	139089	1/40
5	mMC6-D5/3	170029	1/40
6	mMC6-D6/3	139090	1/40
8	mMC6-D8/3	170030	1/40
10	mMC6-D10/3	139091	1/40
12	mMC6-D12/3	170031	1/40
13	mMC6-D13/3	139092	1/40
15	mMC6-D15/3	170032	1/40
16	mMC6-D16/3	139093	1/40
20	mMC6-D20/3	139094	1/40
25	mMC6-D25/3	139095	1/40
32	mMC6-D32/3	139096	1/40
40	mMC6-D40/3	139097	1/40

SG67012



Rated current I_n (A)	Type Designation	Article No.	Units per package
3+N-pole			
1	mMC6-D1/3N	139446	1/30
2	mMC6-D2/3N	139447	1/30
3	mMC6-D3/3N	139448	1/30
4	mMC6-D4/3N	139449	1/30
5	mMC6-D5/3N	170033	1/30
6	mMC6-D6/3N	139450	1/30
8	mMC6-D8/3N	170034	1/30
10	mMC6-D10/3N	139451	1/30
12	mMC6-D12/3N	170035	1/30
13	mMC6-D13/3N	139452	1/30
15	mMC6-D15/3N	170036	1/30
16	mMC6-D16/3N	139453	1/30
20	mMC6-D20/3N	139454	1/30
25	mMC6-D25/3N	139455	1/30
32	mMC6-D32/3N	139456	1/30
40	mMC6-D40/3N	139457	1/30

SG66912



Rated current I_n (A)	Type Designation	Article No.	Units per package
4-pole			
1	mMC6-D1/4	139206	1/30
2	mMC6-D2/4	139207	1/30
3	mMC6-D3/4	139208	1/30
4	mMC6-D4/4	139209	1/30
5	mMC6-D5/4	170037	1/30
6	mMC6-D6/4	139210	1/30
8	mMC6-D8/4	170038	1/30
10	mMC6-D10/4	139211	1/30
12	mMC6-D12/4	170039	1/30
13	mMC6-D13/4	139212	1/30
15	mMC6-D15/4	170040	1/30
16	mMC6-D16/4	139213	1/30
20	mMC6-D20/4	139214	1/30
25	mMC6-D25/4	139215	1/30
32	mMC6-D32/4	139216	1/30
40	mMC6-D40/4	139217	1/30

Rated current I_n (A)	Type Designation	Article No.	Units per package
----------------------------	---------------------	-------------	----------------------

4.5 kA, Characteristic B

SG65412



1-pole

1	mMC4-B1/1	138778	12/120
2	mMC4-B2/1	138779	12/120
3	mMC4-B3/1	138780	12/120
4	mMC4-B4/1	138781	12/120
5	mMC4-B5/1	169883	12/120
6	mMC4-B6/1	138782	12/120
8	mMC4-B8/1	169884	12/120
10	mMC4-B10/1	138783	12/120
12	mMC4-B12/1	169903	12/120
13	mMC4-B13/1	138784	12/120
15	mMC4-B15/1	169904	12/120
16	mMC4-B16/1	138785	12/120
20	mMC4-B20/1	138786	12/120
25	mMC4-B25/1	138787	12/120
32	mMC4-B32/1	138788	12/120
40	mMC4-B40/1	138789	12/120
50	mMC4-B50/1	138790	12/120
63	mMC4-B63/1	138791	12/120

SG66112



1+N-pole, 2 Module Units (MU)

1	mMC4-B1/1N	139258	1/60
2	mMC4-B2/1N	139259	1/60
3	mMC4-B3/1N	139260	1/60
4	mMC4-B4/1N	139261	1/60
5	mMC4-B5/1N	169905	1/60
6	mMC4-B6/1N	139262	1/60
8	mMC4-B8/1N	169906	1/60
10	mMC4-B10/1N	139263	1/60
12	mMC4-B12/1N	169907	1/60
13	mMC4-B13/1N	139264	1/60
15	mMC4-B15/1N	169908	1/60
16	mMC4-B16/1N	139265	1/60
20	mMC4-B20/1N	139266	1/60
25	mMC4-B25/1N	139267	1/60
32	mMC4-B32/1N	139268	1/60
40	mMC4-B40/1N	139269	1/60
50	mMC4-B50/1N	139270	1/60
63	mMC4-B63/1N	139271	1/60

SG66212



2-pole

1	mMC4-B1/2	138898	1/60
2	mMC4-B2/2	138899	1/60
3	mMC4-B3/2	138900	1/60
4	mMC4-B4/2	138901	1/60
5	mMC4-B5/2	169909	1/60
6	mMC4-B6/2	138902	1/60
8	mMC4-B8/2	169910	1/60
10	mMC4-B10/2	138903	1/60
12	mMC4-B12/2	169911	1/60
13	mMC4-B13/2	138904	1/60
15	mMC4-B15/2	169912	1/60
16	mMC4-B16/2	138905	1/60
20	mMC4-B20/2	138906	1/60
25	mMC4-B25/2	138907	1/60
32	mMC4-B32/2	138908	1/60
40	mMC4-B40/2	138909	1/60
50	mMC4-B50/2	138910	1/60
63	mMC4-B63/2	138911	1/60

Miniature Circuit Breakers mMC4

SG66512



Rated current I_n (A)	Type Designation	Article No.	Units per package
3-pole			
1	mMC4-B1/3	139018	1/40
2	mMC4-B2/3	139019	1/40
3	mMC4-B3/3	139020	1/40
4	mMC4-B4/3	139021	1/40
5	mMC4-B5/3	169913	1/40
6	mMC4-B6/3	139022	1/40
8	mMC4-B8/3	169914	1/40
10	mMC4-B10/3	139023	1/40
12	mMC4-B12/3	169915	1/40
13	mMC4-B13/3	139024	1/40
15	mMC4-B15/3	169916	1/40
16	mMC4-B16/3	139025	1/40
20	mMC4-B20/3	139026	1/40
25	mMC4-B25/3	139027	1/40
32	mMC4-B32/3	139028	1/40
40	mMC4-B40/3	139029	1/40
50	mMC4-B50/3	139030	1/40
63	mMC4-B63/3	139031	1/40

SG67012



Rated current I_n (A)	Type Designation	Article No.	Units per package
3+N-pole			
1	mMC4-B1/3N	139378	1/30
2	mMC4-B2/3N	139379	1/30
3	mMC4-B3/3N	139380	1/30
4	mMC4-B4/3N	139381	1/30
5	mMC4-B5/3N	169917	1/30
6	mMC4-B6/3N	139382	1/30
8	mMC4-B58/3N	169918	1/30
10	mMC4-B10/3N	139383	1/30
12	mMC4-B12/3N	169919	1/30
13	mMC4-B13/3N	139384	1/30
15	mMC4-B15/3N	169920	1/30
16	mMC4-B16/3N	139385	1/30
20	mMC4-B20/3N	139386	1/30
25	mMC4-B25/3N	139387	1/30
32	mMC4-B32/3N	139388	1/30
40	mMC4-B40/3N	139389	1/30
50	mMC4-B50/3N	139390	1/30
63	mMC4-B63/3N	139391	1/30

SG66912



Rated current I_n (A)	Type Designation	Article No.	Units per package
4-pole			
1	mMC4-B1/4	139138	1/30
2	mMC4-B2/4	139139	1/30
3	mMC4-B3/4	139140	1/30
4	mMC4-B4/4	139141	1/30
5	mMC4-B5/4	169921	1/30
6	mMC4-B6/4	139142	1/30
8	mMC4-B8/4	169922	1/30
10	mMC4-B10/4	139143	1/30
12	mMC4-B12/4	169923	1/30
13	mMC4-B13/4	139144	1/30
15	mMC4-B15/4	169924	1/30
16	mMC4-B16/4	139145	1/30
20	mMC4-B20/4	139146	1/30
25	mMC4-B25/4	139147	1/30
32	mMC4-B32/4	139148	1/30
40	mMC4-B40/4	139149	1/30
50	mMC4-B50/4	139150	1/30
63	mMC4-B63/4	139151	1/30

Rated current I_n (A)	Type Designation	Article No.	Units per package
----------------------------	---------------------	-------------	----------------------

4.5 kA, Characteristic C

SG65412



1-pole

1	mMC4-C1/1	138792	12/120
2	mMC4-C2/1	138793	12/120
3	mMC4-C3/1	138794	12/120
4	mMC4-C4/1	138795	12/120
5	mMC4-C5/1	169925	12/120
6	mMC4-C6/1	138796	12/120
8	mMC4-C8/1	169926	12/120
10	mMC4-C10/1	138797	12/120
12	mMC4-C12/1	169927	12/120
13	mMC4-C13/1	138798	12/120
15	mMC4-C15/1	169928	12/120
16	mMC4-C16/1	138799	12/120
20	mMC4-C20/1	138800	12/120
25	mMC4-C25/1	138801	12/120
32	mMC4-C32/1	138802	12/120
40	mMC4-C40/1	138803	12/120
50	mMC4-C50/1	138804	12/120
63	mMC4-C63/1	138805	12/120

SG66112



1+N-pole, 2 Module Units (MU)

1	mMC4-C1/1N	139272	1/60
2	mMC4-C2/1N	139273	1/60
3	mMC4-C3/1N	139274	1/60
4	mMC4-C4/1N	139275	1/60
5	mMC4-C5/1N	169929	1/60
6	mMC4-C6/1N	139276	1/60
8	mMC4-C8/1N	169930	1/60
10	mMC4-C10/1N	139277	1/60
12	mMC4-C12/1N	169931	1/60
13	mMC4-C13/1N	139278	1/60
15	mMC4-C15/1N	169932	1/60
16	mMC4-C16/1N	139279	1/60
20	mMC4-C20/1N	139280	1/60
25	mMC4-C25/1N	139281	1/60
32	mMC4-C32/1N	139282	1/60
40	mMC4-C40/1N	139283	1/60
50	mMC4-C50/1N	139284	1/60
63	mMC4-C63/1N	139285	1/60

SG66212



2-pole

1	mMC4-C1/2	138912	1/60
2	mMC4-C2/2	138913	1/60
3	mMC4-C3/2	138914	1/60
4	mMC4-C4/2	138915	1/60
5	mMC4-C5/2	169933	1/60
6	mMC4-C6/2	138916	1/60
8	mMC4-C8/2	169934	1/60
10	mMC4-C10/2	138917	1/60
12	mMC4-C12/2	169935	1/60
13	mMC4-C13/2	138918	1/60
15	mMC4-C15/2	169936	1/60
16	mMC4-C16/2	138919	1/60
20	mMC4-C20/2	138920	1/60
25	mMC4-C25/2	138921	1/60
32	mMC4-C32/2	138922	1/60
40	mMC4-C40/2	138923	1/60
50	mMC4-C50/2	138924	1/60
63	mMC4-C63/2	138925	1/60

Miniature Circuit Breakers mMC4

SG66512



Rated current I_n (A)	Type Designation	Article No.	Units per package
3-pole			
1	mMC4-C1/3	139032	1/40
2	mMC4-C2/3	139033	1/40
3	mMC4-C3/3	139034	1/40
4	mMC4-C4/3	139035	1/40
5	mMC4-C5/3	169937	1/40
6	mMC4-C6/3	139036	1/40
8	mMC4-C8/3	169938	1/40
10	mMC4-C10/3	139037	1/40
12	mMC4-C12/3	169939	1/40
13	mMC4-C13/3	139038	1/40
15	mMC4-C15/3	169940	1/40
16	mMC4-C16/3	139039	1/40
20	mMC4-C20/3	139040	1/40
25	mMC4-C25/3	139041	1/40
32	mMC4-C32/3	139042	1/40
40	mMC4-C40/3	139043	1/40
50	mMC4-C50/3	139044	1/40
63	mMC4-C63/3	139045	1/40

SG67012



Rated current I_n (A)	Type Designation	Article No.	Units per package
3+N-pole			
1	mMC4-C1/3N	139392	1/30
2	mMC4-C2/3N	139393	1/30
3	mMC4-C3/3N	139394	1/30
4	mMC4-C4/3N	139395	1/30
5	mMC4-C5/3N	169885	1/30
6	mMC4-C6/3N	139396	1/30
8	mMC4-C8/3N	169886	1/30
10	mMC4-C10/3N	139397	1/30
12	mMC4-C12/3N	169887	1/30
13	mMC4-C13/3N	139398	1/30
15	mMC4-C15/3N	169888	1/30
16	mMC4-C16/3N	139399	1/30
20	mMC4-C20/3N	139400	1/30
25	mMC4-C25/3N	139401	1/30
32	mMC4-C32/3N	139402	1/30
40	mMC4-C40/3N	139403	1/30
50	mMC4-C50/3N	139404	1/30
63	mMC4-C63/3N	139405	1/30

SG66912



Rated current I_n (A)	Type Designation	Article No.	Units per package
4-pole			
1	mMC4-C1/4	139152	1/30
2	mMC4-C2/4	139153	1/30
3	mMC4-C3/4	139154	1/30
4	mMC4-C4/4	139155	1/30
5	mMC4-C5/4	169889	1/30
6	mMC4-C6/4	139156	1/30
8	mMC4-C8/4	169890	1/30
10	mMC4-C10/4	139157	1/30
12	mMC4-C12/4	169891	1/30
13	mMC4-C13/4	139158	1/30
15	mMC4-C15/4	169892	1/30
16	mMC4-C16/4	139159	1/30
20	mMC4-C20/4	139160	1/30
25	mMC4-C25/4	139161	1/30
32	mMC4-C32/4	139162	1/30
40	mMC4-C40/4	139163	1/30
50	mMC4-C50/4	139164	1/30
63	mMC4-C63/4	139165	1/30

Rated current I_n (A)	Type Designation	Article No.	Units per package
----------------------------	---------------------	-------------	----------------------

4.5 kA, Characteristic D

SG65412



1-pole

1	mMC4-D1/1	138806	12/120
2	mMC4-D2/1	138807	12/120
3	mMC4-D3/1	138808	12/120
4	mMC4-D4/1	138809	12/120
5	mMC4-D5/1	169893	12/120
6	mMC4-D6/1	138810	12/120
8	mMC4-D8/1	169894	12/120
10	mMC4-D10/1	138811	12/120
12	mMC4-D12/1	169895	12/120
13	mMC4-D13/1	138812	12/120
15	mMC4-D15/1	169896	12/120
16	mMC4-D16/1	138813	12/120
20	mMC4-D20/1	138814	12/120
25	mMC4-D25/1	138815	12/120
32	mMC4-D32/1	138816	12/120
40	mMC4-D40/1	138817	12/120

SG66112



1+N-pole, 2 Module Units (MU)

1	mMC4-D1/1N	139286	1/60
2	mMC4-D2/1N	139287	1/60
3	mMC4-D3/1N	139288	1/60
4	mMC4-D4/1N	139289	1/60
5	mMC4-D5/1N	169897	1/60
6	mMC4-D6/1N	139290	1/60
8	mMC4-D8/1N	169898	1/60
10	mMC4-D10/1N	139291	1/60
12	mMC4-D12/1N	169899	1/60
13	mMC4-D13/1N	139292	1/60
15	mMC4-D15/1N	169900	1/60
16	mMC4-D16/1N	139293	1/60
20	mMC4-D20/1N	139294	1/60
25	mMC4-D25/1N	139295	1/60
32	mMC4-D32/1N	139296	1/60
40	mMC4-D40/1N	139297	1/60

SG66212



2-pole

1	mMC4-D1/2	138926	1/60
2	mMC4-D2/2	138927	1/60
3	mMC4-D3/2	138928	1/60
4	mMC4-D4/2	138929	1/60
5	mMC4-D5/2	169901	1/60
6	mMC4-D6/2	138930	1/60
8	mMC4-D8/2	169902	1/60
10	mMC4-D10/2	138931	1/60
12	mMC4-D12/2	169955	1/60
13	mMC4-D13/2	138932	1/60
15	mMC4-D15/2	169956	1/60
16	mMC4-D16/2	138933	1/60
20	mMC4-D20/2	138934	1/60
25	mMC4-D25/2	138935	1/60
32	mMC4-D32/2	138936	1/60
40	mMC4-D40/2	138937	1/60

Miniature Circuit Breakers mMC4

SG66512



Rated current I_n (A)	Type Designation	Article No.	Units per package
3-pole			
1	mMC4-D1/3	139046	1/40
2	mMC4-D2/3	139047	1/40
3	mMC4-D3/3	139048	1/40
4	mMC4-D4/3	139049	1/40
5	mMC4-D5/3	169957	1/40
6	mMC4-D6/3	139050	1/40
8	mMC4-D8/3	169958	1/40
10	mMC4-D10/3	139051	1/40
12	mMC4-D12/3	169959	1/40
13	mMC4-D13/3	139052	1/40
15	mMC4-D15/3	169960	1/40
16	mMC4-D16/3	139053	1/40
20	mMC4-D20/3	139054	1/40
25	mMC4-D25/3	139055	1/40
32	mMC4-D32/3	139056	1/40
40	mMC4-D40/3	139057	1/40

SG67012



Rated current I_n (A)	Type Designation	Article No.	Units per package
3+N-pole			
1	mMC4-D1/3N	139406	1/30
2	mMC4-D2/3N	139407	1/30
3	mMC4-D3/3N	139408	1/30
4	mMC4-D4/3N	139409	1/30
5	mMC4-D5/3N	169961	1/30
6	mMC4-D6/3N	139410	1/30
8	mMC4-D8/3N	169962	1/30
10	mMC4-D10/3N	139411	1/30
12	mMC4-D12/3N	169963	1/30
13	mMC4-D13/3N	139412	1/30
15	mMC4-D15/3N	169964	1/30
16	mMC4-D16/3N	139413	1/30
20	mMC4-D20/3N	139414	1/30
25	mMC4-D25/3N	139415	1/30
32	mMC4-D32/3N	139416	1/30
40	mMC4-D40/3N	139417	1/30

SG66912



Rated current I_n (A)	Type Designation	Article No.	Units per package
4-pole			
1	mMC4-D1/4	139166	1/30
2	mMC4-D2/4	139167	1/30
3	mMC4-D3/4	139168	1/30
4	mMC4-D4/4	139169	1/30
5	mMC4-D5/4	169965	1/30
6	mMC4-D6/4	139170	1/30
8	mMC4-D8/4	169966	1/30
10	mMC4-D10/4	139171	1/30
12	mMC4-D12/4	169967	1/30
13	mMC4-D13/4	139172	1/30
15	mMC4-D15/4	169968	1/30
16	mMC4-D16/4	139173	1/30
20	mMC4-D20/4	139174	1/30
25	mMC4-D25/4	139175	1/30
32	mMC4-D32/4	139176	1/30
40	mMC4-D40/4	139177	1/30

Description	Type Designation	Article No.	Units per package
-------------	---------------------	-------------	----------------------

Terminal covers ASTCVMCBLH for MCB's type mMCT

SG01611



Terminal cover	ASTCVMCBLH		10/600
Terminal cover	ASTCVMCBLHBL		2000

Supplied by Digital Stout Innovation & Trading FZE UAE

Specifications | Miniature Circuit Breakers mMC.

Description

- High selectivity between MCB and back-up fuse due to low let-through energy
- Compatible with standard busbar
- Twin-purpose terminal (lift/open-mouthed) above and below
- Busbar positioning optionally above or below
- Meets the requirements of insulation co-ordination, distance between contacts ≥ 4 mm, for secure isolation
- Suitable for applications up to 48 V DC (use mMCMDC for higher DC voltages)

Accessories:

Auxiliary switch for subsequent installation	ZP-IHK	286052
	ZP-WHK	286053
Tripping signal switch for subsequent installation	ZP-NHK	248437
Remote control and automatic switching device	Z-FW/LP	248296
Shunt trip release	ZP-ASA/..	248438, 248439
Undervoltage release	Z-USA/..	248288-248291
Compact enclosure	KLV-TC-2	276240
	KLV-TC-4	276241
Additional terminal 35 mm ²	Z-HA-EK/35	263960
Switching interlock	Z-IS/SPE-1TE	274418

Connection diagrams

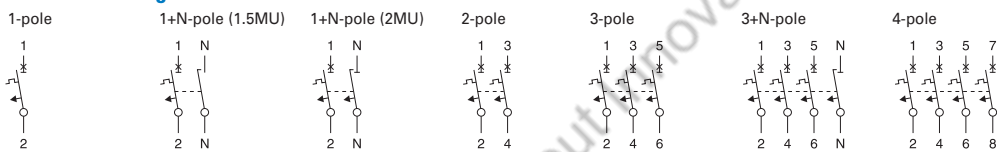

Dimensions (mm)

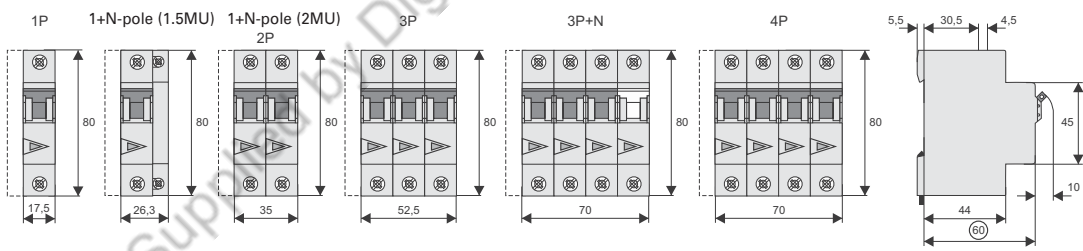

Technical Data

		mMC.
Electrical		
Design according to		IEC/EN 60898-1
Current test marks as printed onto the device		
Rated voltage	U_n	AC: 240/415 V DC: 48 V (per pole)
Rated frequency		50/60 Hz
Rated breaking capacity according to IEC/EN 60898-1	I_{cn}	
mMCM		10 kA
mMC6		6 kA
mMC4		4.5 kA
Characteristic		B, C, D
Back-up fuse		
mMCM		max. 125 A gL
mMC6		max. 100 A gL
mMC4		max. 80 A gL
Selectivity class		3
Rated peak withstand voltage	U_{imp}	4 kV (1.2/50 μ s)
Rated insulation voltage	U_i	440 V
Endurance		
electrical components		$\geq 10,000$ switching operations
mechanical components		$\geq 20,000$ switching operations
Line voltage connection		at will (above/below)
<hr/>		
Design according to		IEC/EN 60947-2
Current test marks as printed onto the device		
Rated voltage	U_n	AC: 230/400 V DC: 60 V (per pole)
Rated frequency		50/60 Hz
Rated breaking capacity according to IEC/EN 60947-2	I_{cn}	
mMCM		15 kA
mMC6		10 kA
mMC4		4.5 kA
Mechanical		
Frame size		45 mm
Device height		80 mm
Device width		17.5 mm per pole (1MU) 26.3 mm: device 1P+N (1.5MU)
Mounting		quick fastening with 3 lock-in positions on DIN rail IEC/EN 60715
Degree of protection		IP20
Upper and lower terminals		open mouthed/lift terminals
Terminal protection		finger and hand touch safe, DGUV VS3, EN 50274
Terminal capacity		1-25 mm ²
(1p+N, 1,5TE)		1-25 mm ² / 1-16 mm ² (N)
Terminal torque		2-2.4 Nm
(1p+N, 1,5TE)		2-2.4 Nm / 1.2-1.5 Nm (N)
Busbar thickness		0.8 - 2 mm (except N 0.5MU)
Mounting		independent of position

Tripping Characteristics (IEC/EN 60898-1)

Tripping characteristic B

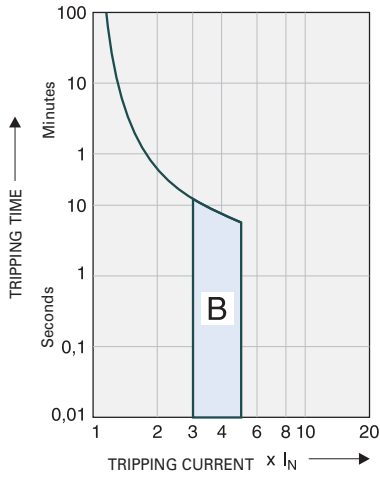

Tripping characteristic C

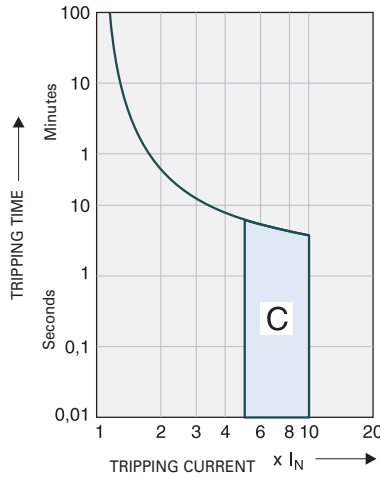

Tripping characteristic D

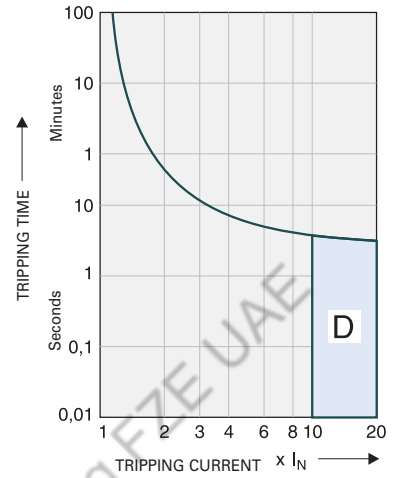

Quick-acting (B), slow (C), very slow (D)

Effect of the Ambient Temperature on Thermal Tripping Behaviour

Adjusted rated current values according to the ambient temperature

I _n [A]	Ambient temperature T [°C]															
	-25	-20	-10	0	10	20	30	35	40	45	50	55	60	65	70	75
0.16	0.20	0.19	0.19	0.18	0.17	0.17	0.16	0.16	0.15	0.15	0.15	0.14	0.14	0.14	0.14	0.13
0.25	0.31	0.30	0.29	0.28	0.27	0.26	0.25	0.25	0.24	0.24	0.23	0.23	0.22	0.22	0.21	0.21
0.5	0.61	0.60	0.58	0.56	0.54	0.52	0.50	0.49	0.48	0.47	0.46	0.45	0.44	0.43	0.42	0.41
0.75	0.92	0.90	0.87	0.84	0.81	0.78	0.75	0.74	0.73	0.71	0.69	0.68	0.66	0.65	0.64	0.62
1	1.2	1.2	1.2	1.1	1.1	1.0	1.0	0.99	0.97	0.95	0.93	0.90	0.89	0.87	0.85	0.83
1.5	1.8	1.8	1.7	1.7	1.6	1.6	1.5	1.5	1.5	1.4	1.4	1.4	1.3	1.3	1.3	1.2
1.6	2.0	1.9	1.9	1.8	1.7	1.7	1.6	1.6	1.5	1.5	1.5	1.4	1.4	1.4	1.4	1.3
2	2.4	2.4	2.3	2.2	2.2	2.1	2.0	2.0	1.9	1.9	1.9	1.8	1.8	1.7	1.7	1.7
2.5	3.1	3.0	2.9	2.8	2.7	2.6	2.5	2.5	2.4	2.4	2.3	2.3	2.2	2.2	2.1	2.1
3	3.7	3.6	3.5	3.4	3.3	3.1	3.0	3.0	2.9	2.8	2.8	2.7	2.7	2.6	2.5	2.5
3.5	4.3	4.2	4.1	3.9	3.8	3.7	3.5	3.4	3.4	3.3	3.2	3.2	3.1	3.0	3.0	2.9
4	4.9	4.8	4.7	4.5	4.3	4.2	4.0	3.9	3.9	3.8	3.7	3.6	3.5	3.5	3.4	3.3
5	6.1	6.0	5.8	5.6	5.4	5.2	5.0	4.9	4.8	4.7	4.6	4.5	4.4	4.3	4.2	4.1
6	7.3	7.2	7.0	6.7	6.5	6.3	6.0	5.9	5.8	5.7	5.6	5.4	5.3	5.2	5.1	5.0
8	9.8	9.6	9.3	9.0	8.7	8.4	8.0	7.9	7.7	7.6	7.4	7.2	7.1	6.9	6.8	6.6
10	12	12	12	11	11	10	10	9.9	9.7	9.5	9.3	9.0	8.9	8.7	8.5	8.3
12	15	14	14	13	13	13	12	12	12	11	11	11	11	10	10	10
13	16	16	15	15	14	14	13	13	13	12	12	12	12	11	11	11
15	18	18	17	17	16	16	15	15	15	14	14	14	14	13	13	13
16	20	19	19	18	17	17	16	16	15	15	15	14	14	14	14	13
20	24	24	23	22	22	21	20	20	19	19	19	18	18	17	17	17
25	31	30	29	28	27	26	25	25	24	24	23	23	22	22	21	21
32	39	38	37	36	35	33	32	32	31	30	30	29	28	28	27	26
40	49	48	47	45	43	42	40	39	39	38	37	36	35	35	34	33
50	61	60	58	56	54	52	50	49	48	47	46	45	44	43	42	41
63	77	76	73	71	68	66	63	62	61	60	58	57	56	55	53	52

Load Capacity of Series Connected Miniature Circuit Breakers

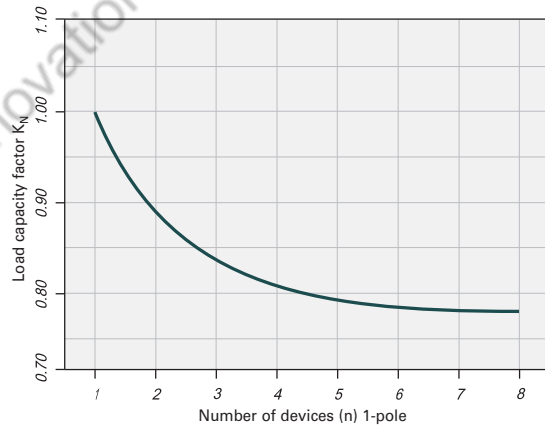

Effect of Power Frequency

Effect of power frequency on the tripping behaviour I_{MA} of the quick release

I _{MA} (f)/I _{MA} (50 Hz) [%]	Power frequency f [Hz]						
	16 ^{2/3}	50	60	100	200	300	400
	91	100	101	106	115	134	141

Let-through Energy mMCM

Let-through Energy mMCM, Characteristic B, 1-pole

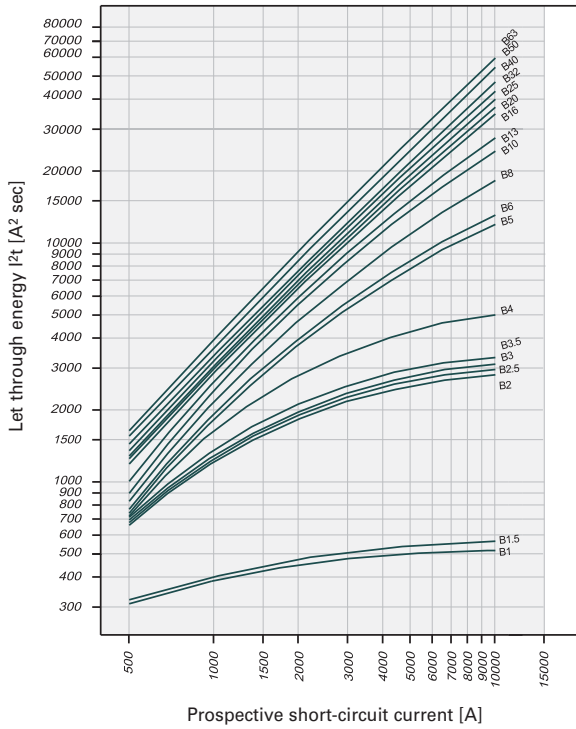

Let-through Energy mMCM, Characteristic C, 1-pole

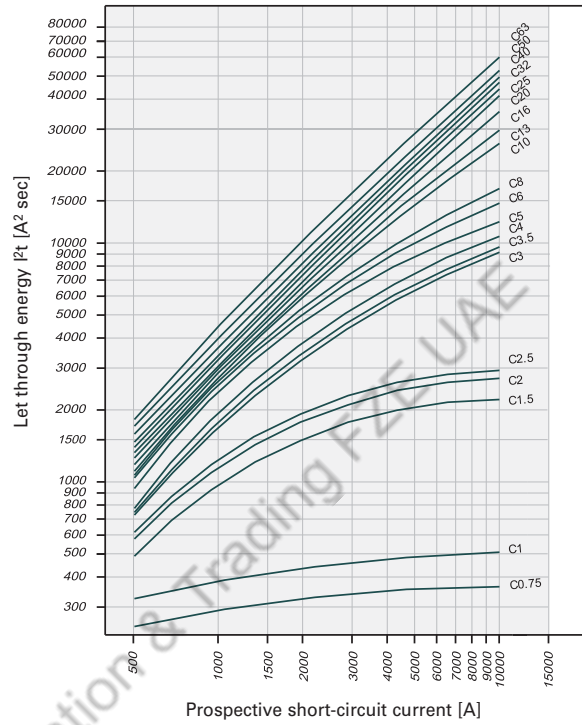

Let-through Energy mMCM, Characteristic D, 1-pole

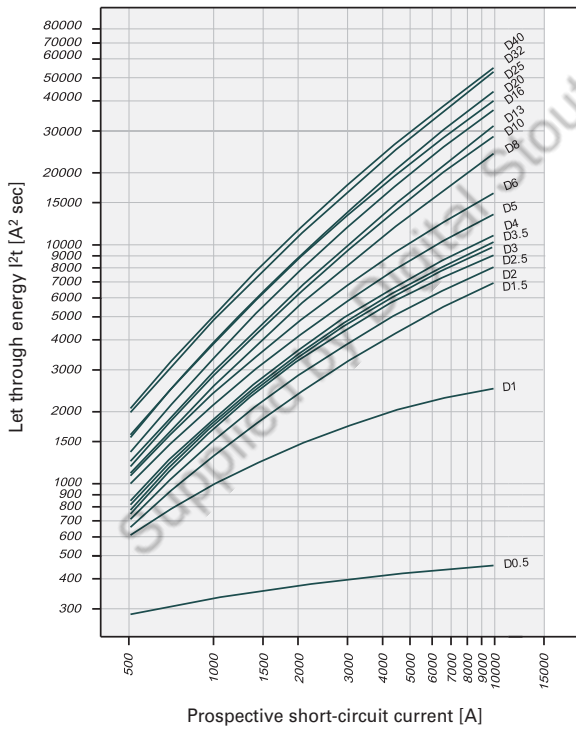

Short Circuit Selectivity mMCM towards DII-DIV fuse link

In case of short circuit, there is selectivity between the miniature circuit breakers mMCM and the upstream fuses up to the specified values of the selectivity limit current I_s [kA] (i. e. in case of short-circuit currents I_{ks} under I_s only the MCB will trip, in case of short circuit currents above this value both protective devices will respond).

*) basically in accordance with EN 60898-1 D.5.2.b

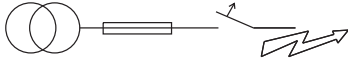

Short circuit selectivity **Characteristic B** towards fuse link **DII-DIV***)

mMCM	DII-DIV gL/gG										
I_n [A]	10	16	20	25	35	50	63	80	100		
1.0	<0.5 ¹⁾	1.2	10.0 ²⁾	10.0 ²⁾	10.0 ²⁾	10.0 ²⁾	10.0 ²⁾	10.0 ²⁾	10.0 ²⁾		
1.5	<0.5 ¹⁾	1.0	10.0 ²⁾	10.0 ²⁾	10.0 ²⁾	10.0 ²⁾	10.0 ²⁾	10.0 ²⁾	10.0 ²⁾		
2.0	<0.5 ¹⁾	<0.5 ¹⁾	0.8	1.6	10.0 ²⁾	10.0 ²⁾	10.0 ²⁾	10.0 ²⁾	10.0 ²⁾		
2.5	<0.5 ¹⁾	<0.5 ¹⁾	0.8	1.5	10.0 ²⁾	10.0 ²⁾	10.0 ²⁾	10.0 ²⁾	10.0 ²⁾		
3.0	<0.5 ¹⁾	<0.5 ¹⁾	0.8	1.4	10.0 ²⁾	10.0 ²⁾	10.0 ²⁾	10.0 ²⁾	10.0 ²⁾		
3.5	<0.5 ¹⁾	<0.5 ¹⁾	0.7	1.3	10.0 ²⁾	10.0 ²⁾	10.0 ²⁾	10.0 ²⁾	10.0 ²⁾		
4	<0.5 ¹⁾	<0.5 ¹⁾	0.6	1.0	3.6	10.0 ²⁾	10.0 ²⁾	10.0 ²⁾	10.0 ²⁾		
5	<0.5 ¹⁾	<0.5 ¹⁾	0.6	0.9	2.0	3.5	8.5	10.0 ²⁾	10.0 ²⁾		
6		<0.5 ¹⁾	0.6	0.9	1.8	3.2	7.4	10.0 ²⁾	10.0 ²⁾		
8		<0.5 ¹⁾	0.5	0.8	1.6	2.6	5.2	8.3	10.0 ²⁾		
10			0.5	0.8	1.4	2.2	3.9	6.0	10.0 ²⁾		
13			0.5	0.7	1.3	2.0	3.6	5.4	10.0 ²⁾		
16				0.6	1.2	1.9	3.2	4.6	8.4		
20					1.2	1.8	3.1	4.4	7.8		
25						1.2	1.8	3.0	4.2	7.3	
32							1.7	2.8	3.9	6.8	
40								2.7	3.8	6.5	
50									2.5	3.5	5.7
63											5.3

Short circuit selectivity **Characteristic C** towards fuse link **DII-DIV***)

mMCM	DII-DIV gL/gG												
I_n [A]	10	16	20	25	35	50	63	80	100				
0.75	1.0	10.0 ²⁾	10.0 ²⁾	10.0 ²⁾	10.0 ²⁾	10.0 ²⁾	10.0 ²⁾	10.0 ²⁾	10.0 ²⁾				
1.0	<0.5 ¹⁾	1.2	10.0 ²⁾	10.0 ²⁾	10.0 ²⁾	10.0 ²⁾	10.0 ²⁾	10.0 ²⁾	10.0 ²⁾				
1.5	<0.5 ¹⁾	<0.5 ¹⁾	1.0	2.2	10.0 ²⁾	10.0 ²⁾	10.0 ²⁾	10.0 ²⁾	10.0 ²⁾				
2.0	<0.5 ¹⁾	<0.5 ¹⁾	0.8	1.6	10.0 ²⁾	10.0 ²⁾	10.0 ²⁾	10.0 ²⁾	10.0 ²⁾				
2.5	<0.5 ¹⁾	<0.5 ¹⁾	0.8	1.4	10.0 ²⁾	10.0 ²⁾	10.0 ²⁾	10.0 ²⁾	10.0 ²⁾				
3.0	<0.5 ¹⁾	<0.5 ¹⁾	0.8	0.9	10.0 ²⁾	10.0 ²⁾	10.0 ²⁾	10.0 ²⁾	10.0 ²⁾				
3.5	<0.5 ¹⁾	<0.5 ¹⁾	0.6	0.9	2.2	4.5	10.0 ²⁾	10.0 ²⁾	10.0 ²⁾				
4	<0.5 ¹⁾	<0.5 ¹⁾	0.6	0.8	1.8	3.6	9.7	10.0 ²⁾	10.0 ²⁾				
5	<0.5 ¹⁾	<0.5 ¹⁾	0.6	0.7	1.5	2.7	7.3	10.0 ²⁾	10.0 ²⁾				
6		<0.5 ¹⁾	0.5	0.6	1.4	2.4	5.5	10.0 ²⁾	10.0 ²⁾				
8		<0.5 ¹⁾	<0.5 ¹⁾	0.6	1.3	2.2	4.7	8.7	10.0 ²⁾				
10		<0.5 ¹⁾	<0.5 ¹⁾	0.6	1.3	2.0	3.6	5.4	10.0 ²⁾				
13							1.3	1.9	3.3	5.0	9.4		
16								1.2	1.8	3.2	4.4	8.0	
20									1.2	1.8	3.1	4.1	7.0
25										1.7	2.8	3.8	6.5
32											2.7	3.7	6.2
40												3.5	5.9
50													5.5
63													

Short circuit selectivity **Characteristic D** towards fuse link **DII-DIV***)

mMCM	DII-DIV gL/gG									
I_n [A]	10	16	20	25	35	50	63	80	100	
0.5	0.5	3.0	10.0 ²⁾	10.0 ²⁾	10.0 ²⁾	10.0 ²⁾	10.0 ²⁾	10.0 ²⁾	10.0 ²⁾	
1.0	<0.5 ¹⁾	<0.5 ¹⁾	1.0	2.4	10.0 ²⁾	10.0 ²⁾	10.0 ²⁾	10.0 ²⁾	10.0 ²⁾	
1.5	<0.5 ¹⁾	<0.5 ¹⁾	0.7	1.2	3.5	7.7	10.0 ²⁾	10.0 ²⁾	10.0 ²⁾	
2.0	<0.5 ¹⁾	<0.5 ¹⁾	0.6	1.0	2.8	5.8	10.0 ²⁾	10.0 ²⁾	10.0 ²⁾	
2.5	<0.5 ¹⁾	<0.5 ¹⁾	0.6	1.4	2.3	4.6	10.0 ²⁾	10.0 ²⁾	10.0 ²⁾	
3.0	<0.5 ¹⁾	<0.5 ¹⁾	0.6	0.9	2.3	4.3	10.0 ²⁾	10.0 ²⁾	10.0 ²⁾	
3.5	<0.5 ¹⁾	<0.5 ¹⁾	0.6	0.9	2.1	4.0	10.0 ²⁾	10.0 ²⁾	10.0 ²⁾	
4		<0.5 ¹⁾	0.6	0.9	2.0	3.8	9.5	10.0 ²⁾	10.0 ²⁾	
5		<0.5 ¹⁾	0.5	0.7	1.7	3.1	7.0	10.0 ²⁾	10.0 ²⁾	
6			0.5	0.7	1.5	2.6	5.3	9.1	10.0 ²⁾	
8			<0.5 ¹⁾	0.7	1.4	2.2	3.9	6.0	10.0 ²⁾	
10				0.7	1.2	1.9	3.4	5.0	9.5	
13					1.2	1.8	3.2	4.6	8.6	
16						1.6	2.7	4.0	7.4	
20							1.5	2.5	3.5	6.7
25								2.4	3.4	6.2
32									2.8	5.0
40										4.8

¹⁾ Selectivity limit current I_s under 0.5 kA

²⁾ Selectivity limit current I_s = rated breaking capacity I_{cn} of the MCB

Darker areas: no selectivity

Short Circuit Selectivity mMCM towards D01-D03 fuse link

In case of short circuit, there is selectivity between the miniature circuit breakers mMCM and the upstream fuses up to the specified values of the selectivity limit current I_s [kA] (i. e. in case of short-circuit currents I_{ks} under I_s only the MCB will trip, in case of short circuit currents above this value both protective devices will respond).

*) basically in accordance with EN 60898-1 D.5.2.b

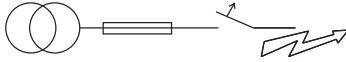

Short circuit selectivity **Characteristic B** towards fuse link **D01-D03***)

mMCM	D01-D03 gL/gG									
I_n [A]	10	16	20	25	35	50	63	80	100	
1.0	<0.5 ¹⁾	10.0 ²⁾	10.0 ²⁾	10.0 ²⁾	10.0 ²⁾	10.0 ²⁾	10.0 ²⁾	10.0 ²⁾	10.0 ²⁾	10.0 ²⁾
1.5	<0.5 ¹⁾	4.1	10.0 ²⁾	10.0 ²⁾	10.0 ²⁾	10.0 ²⁾	10.0 ²⁾	10.0 ²⁾	10.0 ²⁾	10.0 ²⁾
2.0	<0.5 ¹⁾	<0.5 ¹⁾	0.6	1.0	10.0 ²⁾	10.0 ²⁾	10.0 ²⁾	10.0 ²⁾	10.0 ²⁾	10.0 ²⁾
2.5	<0.5 ¹⁾	<0.5 ¹⁾	0.6	1.0	10.0 ²⁾	10.0 ²⁾	10.0 ²⁾	10.0 ²⁾	10.0 ²⁾	10.0 ²⁾
3.0	<0.5 ¹⁾	<0.5 ¹⁾	0.5	1.0	10.0 ²⁾	10.0 ²⁾	10.0 ²⁾	10.0 ²⁾	10.0 ²⁾	10.0 ²⁾
3.5	<0.5 ¹⁾	<0.5 ¹⁾	0.5	0.9	7.0	10.0 ²⁾	10.0 ²⁾	10.0 ²⁾	10.0 ²⁾	10.0 ²⁾
4	<0.5 ¹⁾	<0.5 ¹⁾	0.5	0.9	2.5	10.0 ²⁾	10.0 ²⁾	10.0 ²⁾	10.0 ²⁾	10.0 ²⁾
5		<0.5 ¹⁾	0.5	0.8	1.7	4.0	7.0	10.0 ²⁾	10.0 ²⁾	10.0 ²⁾
6		<0.5 ¹⁾	0.5	0.8	1.6	3.6	6.0	10.0 ²⁾	10.0 ²⁾	10.0 ²⁾
8			0.5	0.8	1.4	2.8	4.3	8.2	10.0 ²⁾	10.0 ²⁾
10			0.5	0.7	1.3	2.4	3.4	6.0	10.0 ²⁾	10.0 ²⁾
13			<0.5 ¹⁾	0.7	1.2	2.3	3.2	5.3	10.0 ²⁾	10.0 ²⁾
16				0.6	1.1	2.2	2.9	4.6	10.0	10.0
20					1.1	2.1	2.8	4.4	9.3	9.3
25						1.1	2.0	2.7	4.2	8.7
32							2.0	2.6	4.0	8.0
40								2.5	3.8	7.5
50								2.3	3.4	6.7
63									6.2	6.2

Short circuit selectivity **Characteristic C** towards fuse link **D01-D03***)

mMCM	D01-D03 gL/gG									
I_n [A]	10	16	20	25	35	50	63	80	100	
0.75	<0.5 ¹⁾	10.0 ²⁾	10.0 ²⁾	10.0 ²⁾	10.0 ²⁾	10.0 ²⁾	10.0 ²⁾	10.0 ²⁾	10.0 ²⁾	10.0 ²⁾
1.0	<0.5 ¹⁾	10.0 ²⁾	10.0 ²⁾	10.0 ²⁾	10.0 ²⁾	10.0 ²⁾	10.0 ²⁾	10.0 ²⁾	10.0 ²⁾	10.0 ²⁾
1.5	<0.5 ¹⁾	0.5	0.6	0.9	10.0 ²⁾	10.0 ²⁾	10.0 ²⁾	10.0 ²⁾	10.0 ²⁾	10.0 ²⁾
2.0	<0.5 ¹⁾	<0.5 ¹⁾	0.5	0.7	10.0 ²⁾	10.0 ²⁾	10.0 ²⁾	10.0 ²⁾	10.0 ²⁾	10.0 ²⁾
2.5	<0.5 ¹⁾	<0.5 ¹⁾	0.5	0.7	10.0 ²⁾	10.0 ²⁾	10.0 ²⁾	10.0 ²⁾	10.0 ²⁾	10.0 ²⁾
3.0	<0.5 ¹⁾	<0.5 ¹⁾	<0.5 ¹⁾	0.6	1.9	5.2	10.0 ²⁾	10.0 ²⁾	10.0 ²⁾	10.0 ²⁾
3.5	<0.5 ¹⁾	<0.5 ¹⁾	<0.5 ¹⁾	0.6	1.8	4.7	9.5	10.0 ²⁾	10.0 ²⁾	10.0 ²⁾
4	<0.5 ¹⁾	<0.5 ¹⁾	<0.5 ¹⁾	0.6	1.6	4.0	7.6	10.0 ²⁾	10.0 ²⁾	10.0 ²⁾
5		<0.5 ¹⁾	<0.5 ¹⁾	0.5	1.3	3.1	5.7	10.0 ²⁾	10.0 ²⁾	10.0 ²⁾
6		<0.5 ¹⁾	<0.5 ¹⁾	<0.5 ¹⁾	1.2	2.7	4.5	10.0 ²⁾	10.0 ²⁾	10.0 ²⁾
8		<0.5 ¹⁾	<0.5 ¹⁾	<0.5 ¹⁾	1.2	2.5	4.0	8.6	10.0 ²⁾	10.0 ²⁾
10		<0.5 ¹⁾	<0.5 ¹⁾	<0.5 ¹⁾	1.2	2.3	3.1	5.4	10.0 ²⁾	10.0 ²⁾
13					1.1	2.2	3.0	4.9	10.0 ²⁾	10.0 ²⁾
16						1.1	2.1	2.8	4.4	9.5
20							1.0	2.0	2.6	8.3
25								1.9	2.5	7.8
32									2.5	7.3
40									3.5	7.0
50										6.5
63										6.5

Short circuit selectivity **Characteristic D** towards fuse link **D01-D03***)

mMCM	D01-D03 gL/gG									
I_n [A]	10	16	20	25	35	50	63	80	100	
0.5	<0.5 ¹⁾	10.0 ²⁾	10.0 ²⁾	10.0 ²⁾	10.0 ²⁾	10.0 ²⁾	10.0 ²⁾	10.0 ²⁾	10.0 ²⁾	10.0 ²⁾
1.0	<0.5 ¹⁾	<0.5 ¹⁾	0.7	1.3	10.0 ²⁾	10.0 ²⁾	10.0 ²⁾	10.0 ²⁾	10.0 ²⁾	10.0 ²⁾
1.5	<0.5 ¹⁾	<0.5 ¹⁾	0.6	0.9	2.8	9.0	10.0 ²⁾	10.0 ²⁾	10.0 ²⁾	10.0 ²⁾
2.0	<0.5 ¹⁾	<0.5 ¹⁾	0.6	0.8	2.2	6.7	10.0 ²⁾	10.0 ²⁾	10.0 ²⁾	10.0 ²⁾
2.5	<0.5 ¹⁾	<0.5 ¹⁾	0.5	0.7	1.9	5.4	10.0 ²⁾	10.0 ²⁾	10.0 ²⁾	10.0 ²⁾
3.0	<0.5 ¹⁾	<0.5 ¹⁾	0.5	0.7	1.8	4.8	9.3	10.0 ²⁾	10.0 ²⁾	10.0 ²⁾
3.5	<0.5 ¹⁾	<0.5 ¹⁾	0.5	0.7	1.7	4.7	8.6	10.0 ²⁾	10.0 ²⁾	10.0 ²⁾
4		<0.5 ¹⁾	0.5	0.7	1.7	4.6	7.7	10.0 ²⁾	10.0 ²⁾	10.0 ²⁾
5		<0.5 ¹⁾	<0.5 ¹⁾	0.6	1.5	3.5	5.8	10.0 ²⁾	10.0 ²⁾	10.0 ²⁾
6		<0.5 ¹⁾	0.5	1.3	2.9	4.5	9.0	10.0 ²⁾	10.0 ²⁾	10.0 ²⁾
8		<0.5 ¹⁾	0.5	1.2	2.4	3.5	6.0	10.0 ²⁾	10.0 ²⁾	10.0 ²⁾
10			0.5	1.1	2.2	3.0	5.0	10.0 ²⁾	10.0 ²⁾	10.0 ²⁾
13				1.1	2.1	2.9	4.6	10.0 ²⁾	10.0 ²⁾	10.0 ²⁾
16					1.9	2.6	3.9	9.0	9.0	9.0
20						1.7	2.3	3.5	8.0	8.0
25							2.2	3.4	7.5	7.5
32								2.9	6.0	6.0
40									5.7	5.7

¹⁾ Selectivity limit current I_s under 0.5 kA

²⁾ Selectivity limit current I_s = rated breaking capacity I_{cn} of the MCB

Darker areas: no selectivity

Short Circuit Selectivity mMCM towards NH-00 fuse link

In case of short circuit, there is selectivity between the miniature circuit breakers mMCM and the upstream fuses up to the specified values of the selectivity limit current I_s [kA] (i. e. in case of short-circuit currents I_{ks} under I_s only the MCB will trip, in case of short circuit currents above this value both protective devices will respond).

*) basically in accordance with EN 60898-1 D.5.2.b

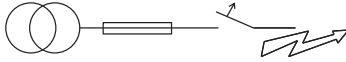

Short circuit selectivity **Characteristic B** towards fuse link **NH-00***)

mMCM	NH-00 gL/gG												
I_n [A]	16	20	25	32	35	40	50	63	80	100	125	160	
1.0	0.9	10.0 ²⁾	10.0 ²⁾	10.0 ²⁾	10.0 ²⁾	10.0 ²⁾	10.0 ²⁾	10.0 ²⁾	10.0 ²⁾	10.0 ²⁾	10.0 ²⁾	10.0 ²⁾	10.0 ²⁾
1.5	0.8	10.0 ²⁾	10.0 ²⁾	10.0 ²⁾	10.0 ²⁾	10.0 ²⁾	10.0 ²⁾	10.0 ²⁾	10.0 ²⁾	10.0 ²⁾	10.0 ²⁾	10.0 ²⁾	10.0 ²⁾
2.0	<0.5 ¹⁾	0.5	1.0	2.5	10.0 ²⁾	10.0 ²⁾	10.0 ²⁾	10.0 ²⁾	10.0 ²⁾	10.0 ²⁾	10.0 ²⁾	10.0 ²⁾	10.0 ²⁾
2.5	<0.5 ¹⁾	0.5	1.0	2.3	10.0 ²⁾	10.0 ²⁾	10.0 ²⁾	10.0 ²⁾	10.0 ²⁾	10.0 ²⁾	10.0 ²⁾	10.0 ²⁾	10.0 ²⁾
3.0	<0.5 ¹⁾	0.5	0.9	2.1	8.0	10.0 ²⁾	10.0 ²⁾	10.0 ²⁾	10.0 ²⁾	10.0 ²⁾	10.0 ²⁾	10.0 ²⁾	10.0 ²⁾
3.5	<0.5 ¹⁾	0.5	0.9	1.8	5.5	10.0 ²⁾	10.0 ²⁾	10.0 ²⁾	10.0 ²⁾	10.0 ²⁾	10.0 ²⁾	10.0 ²⁾	10.0 ²⁾
4	<0.5 ¹⁾	<0.5 ¹⁾	0.8	1.3	2.3	4.3	10.0 ²⁾	10.0 ²⁾	10.0 ²⁾	10.0 ²⁾	10.0 ²⁾	10.0 ²⁾	10.0 ²⁾
5	<0.5 ¹⁾	<0.5 ¹⁾	0.7	1.1	1.6	2.2	3.6	4.8	8.9	10.0 ²⁾	10.0 ²⁾	10.0 ²⁾	10.0 ²⁾
6	<0.5 ¹⁾	<0.5 ¹⁾	0.7	1.1	1.5	2.0	3.3	4.3	7.6	10.0 ²⁾	10.0 ²⁾	10.0 ²⁾	10.0 ²⁾
8	<0.5 ¹⁾	<0.5 ¹⁾	0.6	1.0	1.3	1.7	2.6	3.3	5.2	10.0 ²⁾	10.0 ²⁾	10.0 ²⁾	10.0 ²⁾
10	<0.5 ¹⁾	0.6	0.9	1.2	1.5	2.2	2.7	4.0	9.0	10.0 ²⁾	10.0 ²⁾	10.0 ²⁾	10.0 ²⁾
13	<0.5 ¹⁾	0.6	0.8	1.1	1.4	2.1	2.6	3.8	7.9	10.0 ²⁾	10.0 ²⁾	10.0 ²⁾	10.0 ²⁾
16	<0.5 ¹⁾	0.5	0.7	1.0	1.3	1.9	2.4	3.4	6.4	9.3	10.0 ²⁾	10.0 ²⁾	10.0 ²⁾
20	<0.5 ¹⁾	<0.5 ¹⁾	0.7	1.0	1.3	1.9	2.4	3.3	6.0	8.7	10.0 ²⁾	10.0 ²⁾	10.0 ²⁾
25	<0.5 ¹⁾	<0.5 ¹⁾	0.7	1.0	1.3	1.8	2.3	3.2	5.7	8.0	10.0 ²⁾	10.0 ²⁾	10.0 ²⁾
32	<0.5 ¹⁾	<0.5 ¹⁾	0.9	1.2	1.7	2.2	3.1	5.4	7.6	10.0 ²⁾	10.0 ²⁾	10.0 ²⁾	10.0 ²⁾
40	<0.5 ¹⁾	<0.5 ¹⁾	<0.5 ¹⁾	<0.5 ¹⁾	<0.5 ¹⁾	<0.5 ¹⁾	<0.5 ¹⁾	<0.5 ¹⁾	<0.5 ¹⁾	<0.5 ¹⁾	<0.5 ¹⁾	<0.5 ¹⁾	<0.5 ¹⁾
50	<0.5 ¹⁾	<0.5 ¹⁾	<0.5 ¹⁾	<0.5 ¹⁾	<0.5 ¹⁾	<0.5 ¹⁾	<0.5 ¹⁾	<0.5 ¹⁾	<0.5 ¹⁾	<0.5 ¹⁾	<0.5 ¹⁾	<0.5 ¹⁾	<0.5 ¹⁾
63	<0.5 ¹⁾	<0.5 ¹⁾	<0.5 ¹⁾	<0.5 ¹⁾	<0.5 ¹⁾	<0.5 ¹⁾	<0.5 ¹⁾	<0.5 ¹⁾	<0.5 ¹⁾	<0.5 ¹⁾	<0.5 ¹⁾	<0.5 ¹⁾	<0.5 ¹⁾

Short circuit selectivity **Characteristic C** towards fuse link **NH-00***)

mMCM	NH-00 gL/gG												
I_n [A]	16	20	25	32	35	40	50	63	80	100	125	160	
0.75	10.0 ²⁾	10.0 ²⁾	10.0 ²⁾	10.0 ²⁾	10.0 ²⁾	10.0 ²⁾	10.0 ²⁾	10.0 ²⁾	10.0 ²⁾	10.0 ²⁾	10.0 ²⁾	10.0 ²⁾	10.0 ²⁾
1.0	0.9	10.0 ²⁾	10.0 ²⁾	10.0 ²⁾	10.0 ²⁾	10.0 ²⁾	10.0 ²⁾	10.0 ²⁾	10.0 ²⁾	10.0 ²⁾	10.0 ²⁾	10.0 ²⁾	10.0 ²⁾
1.5	<0.5 ¹⁾	0.6	1.3	4.2	10.0 ²⁾	10.0 ²⁾	10.0 ²⁾	10.0 ²⁾	10.0 ²⁾	10.0 ²⁾	10.0 ²⁾	10.0 ²⁾	10.0 ²⁾
2.0	<0.5 ¹⁾	0.6	1.0	2.5	10.0 ²⁾	10.0 ²⁾	10.0 ²⁾	10.0 ²⁾	10.0 ²⁾	10.0 ²⁾	10.0 ²⁾	10.0 ²⁾	10.0 ²⁾
2.5	<0.5 ¹⁾	0.5	1.0	2.1	10.0 ²⁾	10.0 ²⁾	10.0 ²⁾	10.0 ²⁾	10.0 ²⁾	10.0 ²⁾	10.0 ²⁾	10.0 ²⁾	10.0 ²⁾
3.0	<0.5 ¹⁾	<0.5 ¹⁾	0.7	1.2	1.8	2.6	4.7	6.6	10.0 ²⁾	10.0 ²⁾	10.0 ²⁾	10.0 ²⁾	10.0 ²⁾
3.5	<0.5 ¹⁾	<0.5 ¹⁾	0.7	1.1	1.7	2.4	4.2	6.0	10.0 ²⁾	10.0 ²⁾	10.0 ²⁾	10.0 ²⁾	10.0 ²⁾
4	<0.5 ¹⁾	<0.5 ¹⁾	0.7	1.0	1.5	2.1	3.6	5.0	10.0	10.0	10.0 ²⁾	10.0 ²⁾	10.0 ²⁾
5	<0.5 ¹⁾	<0.5 ¹⁾	0.6	0.8	1.2	1.7	2.8	3.8	8.7	10.0 ²⁾	10.0 ²⁾	10.0 ²⁾	10.0 ²⁾
6	<0.5 ¹⁾	<0.5 ¹⁾	0.5	0.8	1.2	1.5	2.5	3.3	5.7	10.0 ²⁾	10.0 ²⁾	10.0 ²⁾	10.0 ²⁾
8	<0.5 ¹⁾	<0.5 ¹⁾	0.5	0.8	1.1	1.5	2.3	2.9	4.9	10.0 ²⁾	10.0 ²⁾	10.0 ²⁾	10.0 ²⁾
10	<0.5 ¹⁾	<0.5 ¹⁾	0.5	0.7	1.0	1.4	2.0	2.5	3.8	8.0	10.0 ²⁾	10.0 ²⁾	10.0 ²⁾
13	<0.5 ¹⁾	<0.5 ¹⁾	0.5	0.7	1.0	1.3	1.9	2.4	3.6	7.0	10.0 ²⁾	10.0 ²⁾	10.0 ²⁾
16	<0.5 ¹⁾	<0.5 ¹⁾	0.5	0.7	1.0	1.3	1.8	2.3	3.3	6.0	8.8	10.0 ²⁾	10.0 ²⁾
20	<0.5 ¹⁾	<0.5 ¹⁾	0.5	0.7	1.0	1.2	1.7	2.2	3.2	5.5	7.7	10.0 ²⁾	10.0 ²⁾
25	<0.5 ¹⁾	<0.5 ¹⁾	0.5	0.7	1.0	1.2	1.6	2.1	3.0	5.2	7.3	10.0 ²⁾	10.0 ²⁾
32	<0.5 ¹⁾	<0.5 ¹⁾	0.5	0.7	1.0	1.2	1.6	2.1	2.9	5.0	7.0	10.0 ²⁾	10.0 ²⁾
40	<0.5 ¹⁾	<0.5 ¹⁾	0.5	0.7	1.0	1.2	1.6	2.1	2.9	5.0	7.0	10.0 ²⁾	10.0 ²⁾
50	<0.5 ¹⁾	<0.5 ¹⁾	0.5	0.7	1.0	1.2	1.6	2.1	2.9	5.0	7.0	10.0 ²⁾	10.0 ²⁾
63	<0.5 ¹⁾	<0.5 ¹⁾	0.5	0.7	1.0	1.2	1.6	2.1	2.9	5.0	7.0	10.0 ²⁾	10.0 ²⁾

Short circuit selectivity **Characteristic D** towards fuse link **NH-00***)

mMCM	NH-00 gL/gG												
I_n [A]	16	20	25	32	35	40	50	63	80	100	125	160	
0.5	2.1	10.0 ²⁾	10.0 ²⁾	10.0 ²⁾	10.0 ²⁾	10.0 ²⁾	10.0 ²⁾	10.0 ²⁾	10.0 ²⁾	10.0 ²⁾	10.0 ²⁾	10.0 ²⁾	10.0 ²⁾
1.0	<0.5 ¹⁾	0.6	1.4	4.3	10.0 ²⁾	10.0 ²⁾	10.0 ²⁾	10.0 ²⁾	10.0 ²⁾	10.0 ²⁾	10.0 ²⁾	10.0 ²⁾	10.0 ²⁾
1.5	<0.5 ¹⁾	<0.5 ¹⁾	0.9	1.6	2.7	4.0	8.0	10.0 ²⁾	10.0 ²⁾	10.0 ²⁾	10.0 ²⁾	10.0 ²⁾	10.0 ²⁾
2.0	<0.5 ¹⁾	<0.5 ¹⁾	0.8	1.3	2.1	3.1	6.0	8.6	10.0 ²⁾	10.0 ²⁾	10.0 ²⁾	10.0 ²⁾	10.0 ²⁾
2.5	<0.5 ¹⁾	<0.5 ¹⁾	0.7	1.2	1.8	2.6	4.8	6.9	10.0 ²⁾	10.0 ²⁾	10.0 ²⁾	10.0 ²⁾	10.0 ²⁾
3.0	<0.5 ¹⁾	<0.5 ¹⁾	0.7	1.1	1.7	2.4	4.3	6.0	10.0 ²⁾	10.0 ²⁾	10.0 ²⁾	10.0 ²⁾	10.0 ²⁾
3.5	<0.5 ¹⁾	<0.5 ¹⁾	0.7	1.1	1.7	2.4	4.2	5.6	10.0 ²⁾	10.0 ²⁾	10.0 ²⁾	10.0 ²⁾	10.0 ²⁾
4	<0.5 ¹⁾	<0.5 ¹⁾	0.7	1.0	1.6	2.2	3.8	5.2	10.0	10.0 ²⁾	10.0 ²⁾	10.0 ²⁾	10.0 ²⁾
5	<0.5 ¹⁾	<0.5 ¹⁾	0.6	0.9	1.4	1.9	3.2	4.1	7.1	10.0 ²⁾	10.0 ²⁾	10.0 ²⁾	10.0 ²⁾
6	<0.5 ¹⁾	<0.5 ¹⁾	0.5	0.8	1.2	1.6	2.6	3.3	5.5	10.0 ²⁾	10.0 ²⁾	10.0 ²⁾	10.0 ²⁾
8	<0.5 ¹⁾	<0.5 ¹⁾	0.5	0.8	1.1	1.5	2.2	2.7	4.1	8.7	10.0 ²⁾	10.0 ²⁾	10.0 ²⁾
10	<0.5 ¹⁾	<0.5 ¹⁾	0.5	0.7	1.0	1.3	1.9	2.5	3.6	7.2	10.0 ²⁾	10.0 ²⁾	10.0 ²⁾
13	<0.5 ¹⁾	<0.5 ¹⁾	0.5	0.7	1.0	1.3	1.9	2.3	3.4	6.5	9.5	10.0 ²⁾	10.0 ²⁾
16	<0.5 ¹⁾	<0.5 ¹⁾	0.5	0.7	1.0	1.3	1.9	2.3	3.4	6.5	9.5	10.0 ²⁾	10.0 ²⁾
20	<0.5 ¹⁾	<0.5 ¹⁾	0.5	0.7	1.0	1.3	1.9	2.3	3.4	6.5	9.5	10.0 ²⁾	10.0 ²⁾
25	<0.5 ¹⁾	<0.5 ¹⁾	0.5	0.7	1.0	1.3	1.9	2.3	3.4	6.5	9.5	10.0 ²⁾	10.0 ²⁾
32	<0.5 ¹⁾	<0.5 ¹⁾	0.5	0.7	1.0	1.3	1.9	2.3	3.4	6.5	9.5	10.0 ²⁾	10.0 ²⁾
40	<0.5 ¹⁾	<0.5 ¹⁾	0.5	0.7	1.0	1.3	1.9	2.3	3.4	6.5	9.5	10.0 ²⁾	10.0 ²⁾

¹⁾ Selectivity limit current I_s under 0.5 kA

²⁾ Selectivity limit current I_s = rated breaking capacity I_{cn} of the MCB

Darker areas: no selectivity

Short Circuit Selectivity mMCM towards cylindrical fuse links

In case of short circuit, there is selectivity between the miniature circuit breakers mMCM and the upstream fuses up to the specified values of the selectivity limit current I_s [kA] (i. e. in case of short-circuit currents I_{ks} under I_s only the MCB will trip, in case of short circuit currents above this value both protective devices will respond).

*) basically in accordance with EN 60898-1 D.5.2.b

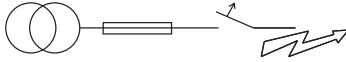

Short circuit selectivity **Characteristic B** towards fuse link **CH10x38 gG, CH14x51 gG, CH22x58 gG*)**

mMCM	CH10x38 gG				CH15x51 gG					CH22x58 gG									
	16	20	25	32	20	25	32	40	50	16	20	25	32	40	50	63	80	100	
1	0.5	>10	>10	>10	>10	>10	>10	>10	>10	1.2	>10	>10	>10	>10	>10	>10	>10	>10	
2	<0.5	0.6	1.2	3.6	0.5	1.0	5.2	>10	>10	<0.5	0.5	1.1	>10	>10	>10	>10	>10	>10	
3	<0.5	0.5	0.8	1.4	0.5	0.9	3.7	>10	>10	<0.5	0.5	1.0	8.0	>10	>10	>10	>10	>10	
4	<0.5	<0.5	0.7	1.2	<0.5	0.7	1.7	4.0	>10	<0.5	<0.5	0.8	2.3	5.1	>10	>10	>10	>10	
6	<0.5	<0.5	0.6	0.9	<0.5	0.7	1.3	2.0	2.7	<0.5	<0.5	0.7	1.5	2.2	2.6	5.6	10	>10	
10	<0.5	<0.5	0.6	0.9	<0.5	0.6	1.1	1.5	2.0	<0.5	<0.5	0.6	1.2	1.6	1.9	3.2	4.8	9.0	
13	<0.5	<0.5	0.6	0.8	<0.5	0.6	1.0	1.4	1.9	<0.5	<0.5	0.6	1.2	1.5	1.7	3.0	4.3	7.7	
16		<0.5	0.5	0.8	<0.5	0.5	1.0	1.4	1.8		<0.5	0.5	1.1	1.4	1.6	2.7	3.8	6.3	
20			0.5	0.8		<0.5	0.9	1.3	1.6			0.5	1.1	1.4	1.6	2.6	3.7	6.0	
25				0.7			0.9	1.3	1.6				1.0	1.3	1.5	2.5	3.5	5.6	
32								1.2	1.5					1.3	1.5	2.4	3.3	5.2	
40									1.5						1.4	2.3	3.2	5.0	
50																2.1	2.9	4.5	
63																	2.8	4.2	

Short circuit selectivity **Characteristic C** towards fuse link **CH10x38 gG, CH14x51 gG, CH22x58 gG*)**

mMCM	CH10x38 gG				CH15x51 gG					CH22x58 gG									
	16	20	25	32	20	25	32	40	50	16	20	25	32	40	50	63	80	100	
0.5	1.9	>10	>10	>10	>10	>10	>10	>10	>10	>10	>10	>10	>10	>10	>10	>10	>10	>10	
1	<0.5	>10	>10	>10	>10	>10	>10	>10	>10	>10	>10	>10	>10	>10	>10	>10	>10	>10	
2	<0.5	0.6	1.2	3.6	0.5	1.0	4.5	>10	>10	<0.5	0.6	1.1	>10	>10	>10	>10	>10	>10	
3	<0.5	0.5	0.8	1.4	<0.5	0.7	1.4	2.4	3.7	<0.5	<0.5	0.8	1.8	2.7	3.5	9.3	>10	>10	
4	<0.5	<0.5	0.7	1.2	<0.5	0.7	1.2	2.0	2.9	<0.5	<0.5	0.7	1.5	2.2	2.7	6.7	>10	>10	
6	<0.5	<0.5	0.6	0.9	<0.5	<0.5	1.0	1.4	2.0	<0.5	<0.5	0.6	1.1	1.6	1.9	4.2	7.0	>10	
10	<0.5	<0.5	0.5	0.8	<0.5	<0.5	0.9	1.3	1.7	<0.5	<0.5	0.6	1.1	1.5	1.8	2.9	4.1	7.5	
13	<0.5	<0.5	0.5	0.8	<0.5	<0.5	0.9	1.3	1.7	<0.5	<0.5	0.5	1.0	1.4	1.7	2.7	3.8	6.5	
16		<0.5	0.5	0.8	<0.5	<0.5	0.8	1.2	1.6		<0.5	<0.5	1.0	1.3	1.5	2.6	3.5	5.8	
20			<0.5	0.7		<0.5	0.8	1.2	1.5			<0.5	0.9	1.2	1.4	2.5	3.3	5.4	
25				0.7			0.8	1.1	1.4				0.9	1.2	1.4	2.3	3.2	5.0	
32								1.1	1.4					1.1	1.3	2.2	3.0	4.8	
40									1.3						1.2	2.0	2.8	4.6	
50																1.9	2.6	4.2	
63																	2.3	3.7	

Short circuit selectivity **Characteristic C** towards fuse link **CH10x38 gG, CH14x51 gG, CH22x58 gG*)**

mMCM	CH10x38 gG				CH15x51 gG					CH22x58 gG									
	16	20	25	32	20	25	32	40	50	16	20	25	32	40	50	63	80	100	
0.5	0.9	>10	>10	>10	>10	>10	>10	>10	>10	>10	>10	>10	>10	>10	>10	>10	>10	>10	
1	<0.5	>10	>10	>10	>10	>10	>10	>10	>10	<0.5	0.6	1.5	>10	>10	>10	>10	>10	>10	
2	<0.5	0.5	0.6	1.6	<0.5	1.0	1.7	>10	>10	<0.5	0.5	0.8	2.1	3.3	4.3	>10	>10	>10	
3	<0.5	<0.5	0.8	1.3	<0.5	0.7	1.4	2.4	3.4	<0.5	<0.5	0.7	1.7	2.5	3.2	8.2	>10	>10	
4	<0.5	<0.5	0.7	1.2	<0.5	0.7	1.3	2.0	3.1	<0.5	<0.5	0.7	1.6	2.3	3.0	7.0	>10	>10	
6	<0.5	<0.5	0.6	1.0	<0.5	<0.5	1.0	1.6	2.0	<0.5	<0.5	0.6	1.3	1.7	2.1	4.2	7.0	>10	
10	<0.5	<0.5	0.6	0.8	<0.5	<0.5	0.9	1.3	1.7	<0.5	<0.5	0.5	1.1	1.4	1.6	2.8	4.1	7.1	
13	<0.5	<0.5	0.5	0.8	<0.5	<0.5	0.9	1.3	1.6	<0.5	<0.5	0.5	1.0	1.4	1.6	2.7	3.8	6.5	
16		<0.5	0.5	0.7	<0.5	<0.5	0.8	1.1	1.4		<0.5	<0.5	1.0	1.2	1.4	2.3	3.2	5.5	
20			<0.5	0.7		<0.5	0.7	1.0	1.3			<0.5	0.8	1.1	1.3	2.1	2.9	4.6	
25				0.7			0.7	1.0	1.2				0.8	1.0	1.2	2.0	2.8	4.0	
32														0.9	1.0	1.7	2.3	3.8	
40															1.0	2.0	2.2	3.6	

Darker areas: no selectivity

Short Circuit Selectivity mMC6 towards DII-DIV fuse link

In case of short circuit, there is selectivity between the miniature circuit breakers mMC6 and the upstream fuses up to the specified values of the selectivity limit current I_s [kA] (i. e. in case of short-circuit currents I_{ks} under I_s only the MCB will trip, in case of short circuit currents above this value both protective devices will respond).

*) basically in accordance with EN 60898-1 D.5.2.b

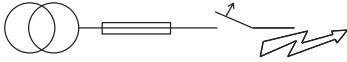

Short circuit selectivity **Characteristic B** towards fuse link **DII-DIV***)

mMC6	DII-DIV gL/gG									
I_n [A]	10	16	20	25	35	50	63	80	100	
1.0	<0.5 ¹⁾	1.2	6.0 ²⁾	6.0 ²⁾	6.0 ²⁾	6.0 ²⁾	6.0 ²⁾	6.0 ²⁾	6.0 ²⁾	6.0 ²⁾
1.5	<0.5 ¹⁾	1.0	6.0 ²⁾	6.0 ²⁾	6.0 ²⁾	6.0 ²⁾	6.0 ²⁾	6.0 ²⁾	6.0 ²⁾	6.0 ²⁾
2.0	<0.5 ¹⁾	<0.5 ¹⁾	0.8	1.6	6.0 ²⁾	6.0 ²⁾	6.0 ²⁾	6.0 ²⁾	6.0 ²⁾	6.0 ²⁾
2.5	<0.5 ¹⁾	<0.5 ¹⁾	0.8	1.5	6.0 ²⁾	6.0 ²⁾	6.0 ²⁾	6.0 ²⁾	6.0 ²⁾	6.0 ²⁾
3.0	<0.5 ¹⁾	<0.5 ¹⁾	0.8	1.4	6.0 ²⁾	6.0 ²⁾	6.0 ²⁾	6.0 ²⁾	6.0 ²⁾	6.0 ²⁾
3.5	<0.5 ¹⁾	<0.5 ¹⁾	0.7	1.3	6.0 ²⁾	6.0 ²⁾	6.0 ²⁾	6.0 ²⁾	6.0 ²⁾	6.0 ²⁾
4	<0.5 ¹⁾	<0.5 ¹⁾	0.6	1.0	3.6	6.0 ²⁾	6.0 ²⁾	6.0 ²⁾	6.0 ²⁾	6.0 ²⁾
5	<0.5 ¹⁾	<0.5 ¹⁾	0.6	0.9	2.0	3.5	6.0 ²⁾	6.0 ²⁾	6.0 ²⁾	6.0 ²⁾
6		<0.5 ¹⁾	0.6	0.9	1.8	3.2	6.0 ²⁾	6.0 ²⁾	6.0 ²⁾	6.0 ²⁾
8		<0.5 ¹⁾	0.5	0.8	1.6	2.6	5.2	6.0 ²⁾	6.0 ²⁾	6.0 ²⁾
10			0.5	0.8	1.4	2.2	3.9	6.0 ²⁾	6.0 ²⁾	6.0 ²⁾
13			0.5	0.7	1.3	2.0	3.6	5.4	6.0 ²⁾	6.0 ²⁾
16				0.6	1.2	1.9	3.2	4.6	6.0 ²⁾	6.0 ²⁾
20					1.2	1.8	3.1	4.4	6.0 ²⁾	6.0 ²⁾
25						1.2	1.8	3.0	4.2	6.0 ²⁾
32							1.7	2.8	3.9	6.0 ²⁾
40								2.7	3.8	6.0 ²⁾
50								2.5	3.5	5.7
63									5.3	6.0 ²⁾

Short circuit selectivity **Characteristic C** towards fuse link **DII-DIV***)

mMC6	DII-DIV gL/gG												
I_n [A]	10	16	20	25	35	50	63	80	100				
0.75	1.0	6.0 ²⁾	6.0 ²⁾	6.0 ²⁾	6.0 ²⁾	6.0 ²⁾	6.0 ²⁾	6.0 ²⁾	6.0 ²⁾	6.0 ²⁾			
1.0	<0.5 ¹⁾	1.2	6.0 ²⁾	6.0 ²⁾	6.0 ²⁾	6.0 ²⁾	6.0 ²⁾	6.0 ²⁾	6.0 ²⁾	6.0 ²⁾			
1.5	<0.5 ¹⁾	<0.5 ¹⁾	1.0	2.2	6.0 ²⁾	6.0 ²⁾	6.0 ²⁾	6.0 ²⁾	6.0 ²⁾	6.0 ²⁾			
2.0	<0.5 ¹⁾	<0.5 ¹⁾	0.8	1.6	6.0 ²⁾	6.0 ²⁾	6.0 ²⁾	6.0 ²⁾	6.0 ²⁾	6.0 ²⁾			
2.5	<0.5 ¹⁾	<0.5 ¹⁾	0.8	1.4	6.0 ²⁾	6.0 ²⁾	6.0 ²⁾	6.0 ²⁾	6.0 ²⁾	6.0 ²⁾			
3.0	<0.5 ¹⁾	<0.5 ¹⁾	0.8	0.9	6.0 ²⁾	6.0 ²⁾	6.0 ²⁾	6.0 ²⁾	6.0 ²⁾	6.0 ²⁾			
3.5	<0.5 ¹⁾	<0.5 ¹⁾	0.6	0.9	2.2	4.5	6.0 ²⁾	6.0 ²⁾	6.0 ²⁾	6.0 ²⁾			
4	<0.5 ¹⁾	<0.5 ¹⁾	0.6	0.8	1.8	3.6	6.0 ²⁾	6.0 ²⁾	6.0 ²⁾	6.0 ²⁾			
5	<0.5 ¹⁾	<0.5 ¹⁾	0.6	0.7	1.5	2.7	6.0 ²⁾	6.0 ²⁾	6.0 ²⁾	6.0 ²⁾			
6		<0.5 ¹⁾	0.5	0.6	1.4	2.4	5.5	6.0 ²⁾	6.0 ²⁾	6.0 ²⁾			
8		<0.5 ¹⁾	<0.5 ¹⁾	0.6	1.3	2.2	4.7	6.0 ²⁾	6.0 ²⁾	6.0 ²⁾			
10			<0.5 ¹⁾	0.6	1.3	2.0	3.6	6.0 ²⁾	6.0 ²⁾	6.0 ²⁾			
13							1.3	1.9	3.3	5.0	6.0 ²⁾		
16								1.2	1.8	3.2	4.4	6.0 ²⁾	
20									1.2	1.8	3.1	4.1	6.0 ²⁾
25										1.7	2.8	3.8	6.0 ²⁾
32											2.7	3.7	6.0 ²⁾
40												3.5	5.9
50													5.5
63													6.0 ²⁾

Short circuit selectivity **Characteristic D** towards fuse link **DII-DIV***)

mMC6	DII-DIV gL/gG									
I_n [A]	10	16	20	25	35	50	63	80	100	
0.5	0.5	3.0	6.0 ²⁾	6.0 ²⁾	6.0 ²⁾	6.0 ²⁾	6.0 ²⁾	6.0 ²⁾	6.0 ²⁾	6.0 ²⁾
1.0	<0.5 ¹⁾	<0.5 ¹⁾	1.0	2.4	6.0 ²⁾	6.0 ²⁾	6.0 ²⁾	6.0 ²⁾	6.0 ²⁾	6.0 ²⁾
1.5	<0.5 ¹⁾	<0.5 ¹⁾	0.7	1.2	3.5	6.0 ²⁾	6.0 ²⁾	6.0 ²⁾	6.0 ²⁾	6.0 ²⁾
2.0	<0.5 ¹⁾	<0.5 ¹⁾	0.6	1.0	2.8	5.8	6.0 ²⁾	6.0 ²⁾	6.0 ²⁾	6.0 ²⁾
2.5	<0.5 ¹⁾	<0.5 ¹⁾	0.6	1.4	2.3	4.6	6.0 ²⁾	6.0 ²⁾	6.0 ²⁾	6.0 ²⁾
3.0	<0.5 ¹⁾	<0.5 ¹⁾	0.6	0.9	2.3	4.3	6.0 ²⁾	6.0 ²⁾	6.0 ²⁾	6.0 ²⁾
3.5	<0.5 ¹⁾	<0.5 ¹⁾	0.6	0.9	2.1	4.0	6.0 ²⁾	6.0 ²⁾	6.0 ²⁾	6.0 ²⁾
4		<0.5 ¹⁾	0.6	0.9	2.0	3.8	6.0 ²⁾	6.0 ²⁾	6.0 ²⁾	6.0 ²⁾
5		<0.5 ¹⁾	0.5	0.7	1.7	3.1	6.0 ²⁾	6.0 ²⁾	6.0 ²⁾	6.0 ²⁾
6			0.5	0.7	1.5	2.6	5.3	6.0 ²⁾	6.0 ²⁾	6.0 ²⁾
8			<0.5 ¹⁾	0.7	1.4	2.2	3.9	6.0 ²⁾	6.0 ²⁾	6.0 ²⁾
10				0.7	1.2	1.9	3.4	5.0	6.0 ²⁾	6.0 ²⁾
13					1.2	1.8	3.2	4.6	6.0 ²⁾	6.0 ²⁾
16						1.6	2.7	4.0	6.0 ²⁾	6.0 ²⁾
20							1.5	2.5	3.5	6.0 ²⁾
25								2.4	3.4	6.0 ²⁾
32									2.8	5.0
40										4.8

¹⁾ Selectivity limit current I_s under 0.5 kA

²⁾ Selectivity limit current I_s = rated breaking capacity I_{cn} of the MCB

Darker areas: no selectivity

Short Circuit Selectivity mMC6 towards D01-D03 fuse link

In case of short circuit, there is selectivity between the miniature circuit breakers mMC6 and the upstream fuses up to the specified values of the selectivity limit current I_s [kA] (i. e. in case of short-circuit currents I_{ks} under I_s only the MCB will trip, in case of short circuit currents above this value both protective devices will respond).

*) basically in accordance with EN 60898-1 D.5.2.b

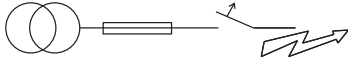

Short circuit selectivity **Characteristic B** towards fuse link **D01-D03***)

mMC6	D01-D03 gL/gG										
I_n [A]	10	16	20	25	35	50	63	80	100		
1.0	<0.5 ¹⁾	6.0 ²⁾	6.0 ²⁾	6.0 ²⁾	6.0 ²⁾	6.0 ²⁾	6.0 ²⁾	6.0 ²⁾	6.0 ²⁾	6.0 ²⁾	
1.5	<0.5 ¹⁾	4.1	6.0 ²⁾	6.0 ²⁾	6.0 ²⁾	6.0 ²⁾	6.0 ²⁾	6.0 ²⁾	6.0 ²⁾	6.0 ²⁾	
2.0	<0.5 ¹⁾	<0.5 ¹⁾	0.6	1.0	6.0 ²⁾	6.0 ²⁾	6.0 ²⁾	6.0 ²⁾	6.0 ²⁾	6.0 ²⁾	
2.5	<0.5 ¹⁾	<0.5 ¹⁾	0.6	1.0	6.0 ²⁾	6.0 ²⁾	6.0 ²⁾	6.0 ²⁾	6.0 ²⁾	6.0 ²⁾	
3.0	<0.5 ¹⁾	<0.5 ¹⁾	0.5	1.0	6.0 ²⁾	6.0 ²⁾	6.0 ²⁾	6.0 ²⁾	6.0 ²⁾	6.0 ²⁾	
3.5	<0.5 ¹⁾	<0.5 ¹⁾	0.5	0.9	6.0 ²⁾	6.0 ²⁾	6.0 ²⁾	6.0 ²⁾	6.0 ²⁾	6.0 ²⁾	
4	<0.5 ¹⁾	<0.5 ¹⁾	0.5	0.9	2.5	6.0 ²⁾	6.0 ²⁾	6.0 ²⁾	6.0 ²⁾	6.0 ²⁾	
5		<0.5 ¹⁾	0.5	0.8	1.7	4.0	6.0 ²⁾	6.0 ²⁾	6.0 ²⁾	6.0 ²⁾	
6		<0.5 ¹⁾	0.5	0.8	1.6	3.6	6.0 ²⁾	6.0 ²⁾	6.0 ²⁾	6.0 ²⁾	
8			0.5	0.8	1.4	2.8	4.3	6.0 ²⁾	6.0 ²⁾	6.0 ²⁾	
10			0.5	0.7	1.3	2.4	3.4	6.0 ²⁾	6.0 ²⁾	6.0 ²⁾	
13			<0.5 ¹⁾	0.7	1.2	2.3	3.2	5.3	6.0 ²⁾	6.0 ²⁾	
16				0.6	1.1	2.2	2.9	4.6	6.0 ²⁾	6.0 ²⁾	
20					1.1	2.1	2.8	4.4	6.0 ²⁾	6.0 ²⁾	
25						1.1	2.0	2.7	4.2	6.0 ²⁾	
32							2.0	2.6	4.0	6.0 ²⁾	
40								2.5	3.8	6.0 ²⁾	
50									2.3	3.4	6.0 ²⁾
63										6.0 ²⁾	6.0 ²⁾

Short circuit selectivity **Characteristic C** towards fuse link **D01-D03***)

mMC6	D01-D03 gL/gG											
I_n [A]	10	16	20	25	35	50	63	80	100			
0.75	<0.5 ¹⁾	6.0 ²⁾	6.0 ²⁾	6.0 ²⁾	6.0 ²⁾	6.0 ²⁾	6.0 ²⁾	6.0 ²⁾	6.0 ²⁾	6.0 ²⁾		
1.0	<0.5 ¹⁾	6.0 ²⁾	6.0 ²⁾	6.0 ²⁾	6.0 ²⁾	6.0 ²⁾	6.0 ²⁾	6.0 ²⁾	6.0 ²⁾	6.0 ²⁾		
1.5	<0.5 ¹⁾	0.5	0.6	0.9	6.0 ²⁾	6.0 ²⁾	6.0 ²⁾	6.0 ²⁾	6.0 ²⁾	6.0 ²⁾		
2.0	<0.5 ¹⁾	<0.5 ¹⁾	0.5	0.7	6.0 ²⁾	6.0 ²⁾	6.0 ²⁾	6.0 ²⁾	6.0 ²⁾	6.0 ²⁾		
2.5	<0.5 ¹⁾	<0.5 ¹⁾	0.5	0.7	6.0 ²⁾	6.0 ²⁾	6.0 ²⁾	6.0 ²⁾	6.0 ²⁾	6.0 ²⁾		
3.0	<0.5 ¹⁾	<0.5 ¹⁾	<0.5 ¹⁾	0.6	1.9	5.2	6.0 ²⁾	6.0 ²⁾	6.0 ²⁾	6.0 ²⁾		
3.5	<0.5 ¹⁾	<0.5 ¹⁾	<0.5 ¹⁾	0.6	1.8	4.7	6.0 ²⁾	6.0 ²⁾	6.0 ²⁾	6.0 ²⁾		
4	<0.5 ¹⁾	<0.5 ¹⁾	<0.5 ¹⁾	0.6	1.6	4.0	6.0 ²⁾	6.0 ²⁾	6.0 ²⁾	6.0 ²⁾		
5		<0.5 ¹⁾	<0.5 ¹⁾	0.5	1.3	3.1	5.7	6.0 ²⁾	6.0 ²⁾	6.0 ²⁾		
6		<0.5 ¹⁾	<0.5 ¹⁾	<0.5 ¹⁾	1.2	2.7	4.5	6.0 ²⁾	6.0 ²⁾	6.0 ²⁾		
8		<0.5 ¹⁾	<0.5 ¹⁾	<0.5 ¹⁾	1.2	2.5	4.0	6.0 ²⁾	6.0 ²⁾	6.0 ²⁾		
10			<0.5 ¹⁾	<0.5 ¹⁾	1.2	2.3	3.1	5.4	6.0 ²⁾	6.0 ²⁾		
13						1.1	2.2	3.0	4.9	6.0 ²⁾		
16							1.1	2.1	2.8	4.4	6.0 ²⁾	
20								1.0	2.0	2.6	4.0	6.0 ²⁾
25									1.9	2.5	3.8	6.0 ²⁾
32										2.5	3.7	6.0 ²⁾
40											3.5	6.0 ²⁾
50												6.0 ²⁾
63												6.0 ²⁾

Short circuit selectivity **Characteristic D** towards fuse link **D01-D03***)

mMC6	D01-D03 gL/gG									
I_n [A]	10	16	20	25	35	50	63	80	100	
0.5	<0.5 ¹⁾	6.0 ²⁾	6.0 ²⁾	6.0 ²⁾	6.0 ²⁾	6.0 ²⁾	6.0 ²⁾	6.0 ²⁾	6.0 ²⁾	6.0 ²⁾
1.0	<0.5 ¹⁾	<0.5 ¹⁾	0.7	1.3	6.0 ²⁾	6.0 ²⁾	6.0 ²⁾	6.0 ²⁾	6.0 ²⁾	6.0 ²⁾
1.5	<0.5 ¹⁾	<0.5 ¹⁾	0.6	0.9	2.8	6.0 ²⁾	6.0 ²⁾	6.0 ²⁾	6.0 ²⁾	6.0 ²⁾
2.0	<0.5 ¹⁾	<0.5 ¹⁾	0.6	0.8	2.2	6.0 ²⁾	6.0 ²⁾	6.0 ²⁾	6.0 ²⁾	6.0 ²⁾
2.5	<0.5 ¹⁾	<0.5 ¹⁾	0.5	0.7	1.9	5.4	6.0 ²⁾	6.0 ²⁾	6.0 ²⁾	6.0 ²⁾
3.0	<0.5 ¹⁾	<0.5 ¹⁾	0.5	0.7	1.8	4.8	6.0 ²⁾	6.0 ²⁾	6.0 ²⁾	6.0 ²⁾
3.5	<0.5 ¹⁾	<0.5 ¹⁾	0.5	0.7	1.7	4.7	6.0 ²⁾	6.0 ²⁾	6.0 ²⁾	6.0 ²⁾
4		<0.5 ¹⁾	0.5	0.7	1.7	4.6	6.0 ²⁾	6.0 ²⁾	6.0 ²⁾	6.0 ²⁾
5		<0.5 ¹⁾	<0.5 ¹⁾	0.6	1.5	3.5	5.8	6.0 ²⁾	6.0 ²⁾	6.0 ²⁾
6		<0.5 ¹⁾	0.5	1.3	2.9	4.5	6.0 ²⁾	6.0 ²⁾	6.0 ²⁾	6.0 ²⁾
8			<0.5 ¹⁾	0.5	1.2	2.4	3.5	6.0 ²⁾	6.0 ²⁾	6.0 ²⁾
10				0.5	1.1	2.2	3.0	5.0	6.0 ²⁾	6.0 ²⁾
13					1.1	2.1	2.9	4.6	6.0 ²⁾	6.0 ²⁾
16						1.9	2.6	3.9	6.0 ²⁾	6.0 ²⁾
20							1.7	2.3	3.5	6.0 ²⁾
25								2.2	3.4	6.0 ²⁾
32									2.9	6.0 ²⁾
40										5.7

¹⁾ Selectivity limit current I_s under 0.5 kA

²⁾ Selectivity limit current I_s = rated breaking capacity I_{cn} of the MCB

Darker areas: no selectivity

Short Circuit Selectivity mMC6 towards NH-00 fuse link

In case of short circuit, there is selectivity between the miniature circuit breakers mMC6 and the upstream fuses up to the specified values of the selectivity limit current I_s [kA] (i. e. in case of short-circuit currents I_{ks} under I_s only the MCB will trip, in case of short circuit currents above this value both protective devices will respond).

*) basically in accordance with EN 60898-1 D.5.2.b

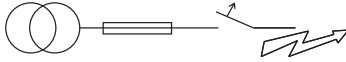

Short circuit selectivity **Characteristic B** towards fuse link **NH-00***

mMC6	NH-00 gL/gG												
I_n [A]	16	20	25	32	35	40	50	63	80	100	125	160	
1.0	0.9	6.0 ²⁾	6.0 ²⁾	6.0 ²⁾	6.0 ²⁾	6.0 ²⁾	6.0 ²⁾	6.0 ²⁾	6.0 ²⁾	6.0 ²⁾	6.0 ²⁾	6.0 ²⁾	
1.5	0.8	6.0 ²⁾	6.0 ²⁾	6.0 ²⁾	6.0 ²⁾	6.0 ²⁾	6.0 ²⁾	6.0 ²⁾	6.0 ²⁾	6.0 ²⁾	6.0 ²⁾	6.0 ²⁾	
2.0	<0.5 ¹⁾	0.5	1.0	2.5	6.0 ²⁾	6.0 ²⁾	6.0 ²⁾	6.0 ²⁾	6.0 ²⁾	6.0 ²⁾	6.0 ²⁾	6.0 ²⁾	
2.5	<0.5 ¹⁾	0.5	1.0	2.3	6.0 ²⁾	6.0 ²⁾	6.0 ²⁾	6.0 ²⁾	6.0 ²⁾	6.0 ²⁾	6.0 ²⁾	6.0 ²⁾	
3.0	<0.5 ¹⁾	0.5	0.9	2.1	6.0 ²⁾	6.0 ²⁾	6.0 ²⁾	6.0 ²⁾	6.0 ²⁾	6.0 ²⁾	6.0 ²⁾	6.0 ²⁾	
3.5	<0.5 ¹⁾	0.5	0.9	1.8	5.5	6.0 ²⁾	6.0 ²⁾	6.0 ²⁾	6.0 ²⁾	6.0 ²⁾	6.0 ²⁾	6.0 ²⁾	
4	<0.5 ¹⁾	<0.5 ¹⁾	0.8	1.3	2.3	4.3	6.0 ²⁾	6.0 ²⁾	6.0 ²⁾	6.0 ²⁾	6.0 ²⁾	6.0 ²⁾	
5	<0.5 ¹⁾	<0.5 ¹⁾	0.7	1.1	1.6	2.2	3.6	4.8	6.0 ²⁾	6.0 ²⁾	6.0 ²⁾	6.0 ²⁾	
6	<0.5 ¹⁾	<0.5 ¹⁾	0.7	1.1	1.5	2.0	3.3	4.3	6.0 ²⁾	6.0 ²⁾	6.0 ²⁾	6.0 ²⁾	
8	<0.5 ¹⁾	<0.5 ¹⁾	0.6	1.0	1.3	1.7	2.6	3.3	5.2	6.0 ²⁾	6.0 ²⁾	6.0 ²⁾	
10	<0.5 ¹⁾	0.6	0.9	1.2	1.5	2.2	2.7	4.0	6.0 ²⁾	6.0 ²⁾	6.0 ²⁾		
13	<0.5 ¹⁾	0.6	0.8	1.1	1.4	2.1	2.6	3.8	6.0 ²⁾	6.0 ²⁾	6.0 ²⁾		
16		0.5	0.7	1.0	1.3	1.9	2.4	3.4	6.0 ²⁾	6.0 ²⁾	6.0 ²⁾		
20			0.7	1.0	1.3	1.9	2.4	3.3	6.0 ²⁾	6.0 ²⁾	6.0 ²⁾		
25			0.7	1.0	1.3	1.8	2.3	3.2	5.7	6.0 ²⁾	6.0 ²⁾		
32				0.9	1.2	1.7	2.2	3.1	5.4	6.0 ²⁾	6.0 ²⁾		
40								2.1	3.0	5.1	6.0 ²⁾	6.0 ²⁾	
50								1.9	2.8	4.7	6.0 ²⁾	6.0 ²⁾	
63									4.4	6.0 ²⁾	6.0 ²⁾		

Short circuit selectivity **Characteristic C** towards fuse link **NH-00***

mMC6	NH-00 gL/gG													
I_n [A]	16	20	25	32	35	40	50	63	80	100	125	160		
0.75	6.0 ²⁾	6.0 ²⁾	6.0 ²⁾	6.0 ²⁾	6.0 ²⁾	6.0 ²⁾	6.0 ²⁾	6.0 ²⁾	6.0 ²⁾	6.0 ²⁾	6.0 ²⁾	6.0 ²⁾		
1.0	0.9	6.0 ²⁾	6.0 ²⁾	6.0 ²⁾	6.0 ²⁾	6.0 ²⁾	6.0 ²⁾	6.0 ²⁾	6.0 ²⁾	6.0 ²⁾	6.0 ²⁾	6.0 ²⁾		
1.5	<0.5 ¹⁾	0.6	1.3	4.2	6.0 ²⁾	6.0 ²⁾	6.0 ²⁾	6.0 ²⁾	6.0 ²⁾	6.0 ²⁾	6.0 ²⁾	6.0 ²⁾		
2.0	<0.5 ¹⁾	0.6	1.0	2.5	6.0 ²⁾	6.0 ²⁾	6.0 ²⁾	6.0 ²⁾	6.0 ²⁾	6.0 ²⁾	6.0 ²⁾	6.0 ²⁾		
2.5	<0.5 ¹⁾	0.5	1.0	2.1	6.0 ²⁾	6.0 ²⁾	6.0 ²⁾	6.0 ²⁾	6.0 ²⁾	6.0 ²⁾	6.0 ²⁾	6.0 ²⁾		
3.0	<0.5 ¹⁾	<0.5 ¹⁾	0.7	1.2	1.8	2.6	4.7	6.0 ²⁾	6.0 ²⁾	6.0 ²⁾	6.0 ²⁾	6.0 ²⁾		
3.5	<0.5 ¹⁾	<0.5 ¹⁾	0.7	1.1	1.7	2.4	4.2	6.0 ²⁾	6.0 ²⁾	6.0 ²⁾	6.0 ²⁾	6.0 ²⁾		
4	<0.5 ¹⁾	<0.5 ¹⁾	0.7	1.0	1.5	2.1	3.6	5.0	6.0 ²⁾	6.0 ²⁾	6.0 ²⁾	6.0 ²⁾		
5	<0.5 ¹⁾	<0.5 ¹⁾	0.6	0.8	1.2	1.7	2.8	3.8	6.0 ²⁾	6.0 ²⁾	6.0 ²⁾	6.0 ²⁾		
6	<0.5 ¹⁾	<0.5 ¹⁾	0.5	0.8	1.2	1.5	2.5	3.3	5.7	6.0 ²⁾	6.0 ²⁾	6.0 ²⁾		
8	<0.5 ¹⁾	<0.5 ¹⁾	0.5	0.8	1.1	1.5	2.3	2.9	4.9	6.0 ²⁾	6.0 ²⁾	6.0 ²⁾		
10			0.5	0.7	1.0	1.4	2.0	2.5	3.8	6.0 ²⁾	6.0 ²⁾	6.0 ²⁾		
13					1.0	1.3	1.9	2.4	3.6	6.0 ²⁾	6.0 ²⁾	6.0 ²⁾		
16						1.0	1.3	1.8	2.3	3.3	6.0 ²⁾	6.0 ²⁾		
20							1.0	1.2	1.7	2.2	3.2	5.5	6.0 ²⁾	6.0 ²⁾
25								1.6	2.1	3.0	5.2	6.0 ²⁾	6.0 ²⁾	
32									2.1	2.9	5.0	6.0 ²⁾	6.0 ²⁾	
40										2.8	4.8	6.0 ²⁾	6.0 ²⁾	
50											4.5	6.0 ²⁾	6.0 ²⁾	
63												5.9	6.0 ²⁾	

Short circuit selectivity **Characteristic D** towards fuse link **NH-00***

mMC6	NH-00 gL/gG											
I_n [A]	16	20	25	32	35	40	50	63	80	100	125	160
0.5	2.1	6.0 ²⁾	6.0 ²⁾	6.0 ²⁾	6.0 ²⁾	6.0 ²⁾	6.0 ²⁾	6.0 ²⁾	6.0 ²⁾	6.0 ²⁾	6.0 ²⁾	6.0 ²⁾
1.0	<0.5 ¹⁾	0.6	1.4	4.3	6.0 ²⁾	6.0 ²⁾	6.0 ²⁾	6.0 ²⁾	6.0 ²⁾	6.0 ²⁾	6.0 ²⁾	6.0 ²⁾
1.5	<0.5 ¹⁾	<0.5 ¹⁾	0.9	1.6	2.7	4.0	6.0 ²⁾	6.0 ²⁾	6.0 ²⁾	6.0 ²⁾	6.0 ²⁾	6.0 ²⁾
2.0	<0.5 ¹⁾	<0.5 ¹⁾	0.8	1.3	2.1	3.1	6.0 ²⁾	6.0 ²⁾	6.0 ²⁾	6.0 ²⁾	6.0 ²⁾	6.0 ²⁾
2.5	<0.5 ¹⁾	<0.5 ¹⁾	0.7	1.2	1.8	2.6	4.8	6.0 ²⁾	6.0 ²⁾	6.0 ²⁾	6.0 ²⁾	6.0 ²⁾
3.0	<0.5 ¹⁾	<0.5 ¹⁾	0.7	1.1	1.7	2.4	4.3	6.0 ²⁾	6.0 ²⁾	6.0 ²⁾	6.0 ²⁾	6.0 ²⁾
3.5	<0.5 ¹⁾	<0.5 ¹⁾	0.7	1.1	1.7	2.4	4.2	5.6	6.0 ²⁾	6.0 ²⁾	6.0 ²⁾	6.0 ²⁾
4	<0.5 ¹⁾	<0.5 ¹⁾	0.7	1.0	1.6	2.2	3.8	5.2	6.0 ²⁾	6.0 ²⁾	6.0 ²⁾	6.0 ²⁾
5		<0.5 ¹⁾	0.6	0.9	1.4	1.9	3.2	4.1	6.0 ²⁾	6.0 ²⁾	6.0 ²⁾	6.0 ²⁾
6		<0.5 ¹⁾	0.5	0.8	1.2	1.6	2.6	3.3	5.5	6.0 ²⁾	6.0 ²⁾	6.0 ²⁾
8			0.5	0.8	1.1	1.5	2.2	2.7	4.1	6.0 ²⁾	6.0 ²⁾	6.0 ²⁾
10			0.5	0.7	1.0	1.3	1.9	2.5	3.6	6.0 ²⁾	6.0 ²⁾	6.0 ²⁾
13				1.0	1.3	1.9	2.3	3.4	6.0 ²⁾	6.0 ²⁾	6.0 ²⁾	
16					1.1	1.6	2.0	3.0	5.5	6.0 ²⁾	6.0 ²⁾	
20						1.4	1.8	2.8	5.0	6.0 ²⁾	6.0 ²⁾	
25							1.8	2.7	4.8	6.0 ²⁾	6.0 ²⁾	
32								2.4	4.1	6.0 ²⁾	6.0 ²⁾	
40									4.0	6.0 ²⁾	6.0 ²⁾	

¹⁾ Selectivity limit current I_s under 0.5 kA

²⁾ Selectivity limit current I_s = rated breaking capacity I_{cn} of the MCB

Darker areas: no selectivity

Let-through Energy mMC4

Let-through Energy mMC4, Characteristic B, 1-pole

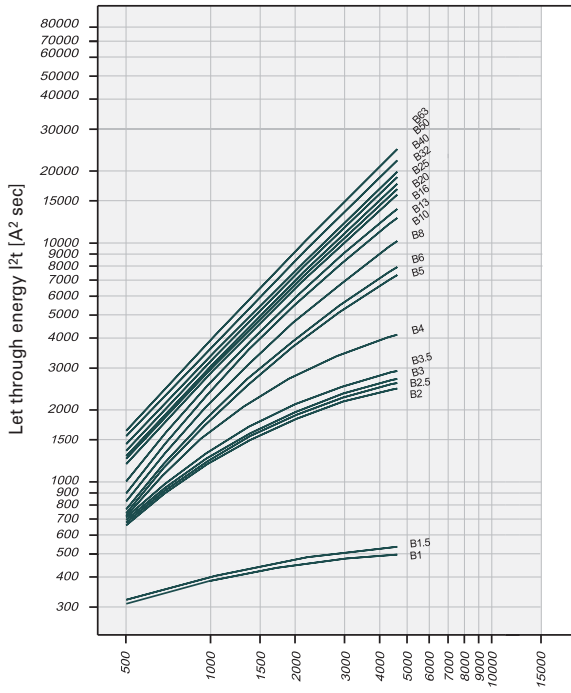

Let-through Energy mMC4, Characteristic C, 1-pole

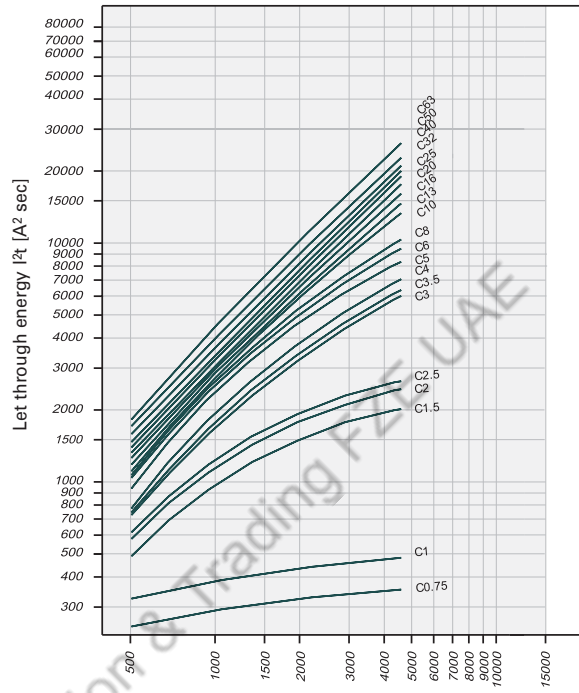

Short Circuit Selectivity mMC4 towards DII-DIV fuse link

In case of short circuit, there is selectivity between the miniature circuit breakers mMC4 and the upstream fuses up to the specified values of the selectivity limit current I_s [kA] (i. e. in case of short-circuit currents I_{ks} under I_s only the MCB will trip, in case of short circuit currents above this value both protective devices will respond).

*) basically in accordance with EN 60898-1 D.5.2.b

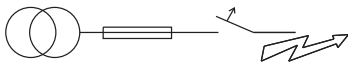

Short circuit selectivity **Characteristic B** towards fuse link **DII-DIV***)

mMC4	DII-DIV gL/gG									
I_n [A]	10	16	20	25	35	50	63	80	100	
1.0	<0.5 ¹⁾	1.2	4.5 ²⁾	4.5 ²⁾	4.5 ²⁾	4.5 ²⁾	4.5 ²⁾	4.5 ²⁾	4.5 ²⁾	4.5 ²⁾
1.5	<0.5 ¹⁾	1.0	4.5 ²⁾	4.5 ²⁾	4.5 ²⁾	4.5 ²⁾	4.5 ²⁾	4.5 ²⁾	4.5 ²⁾	4.5 ²⁾
2.0	<0.5 ¹⁾	<0.5 ¹⁾	0.8	1.6	4.5 ²⁾	4.5 ²⁾	4.5 ²⁾	4.5 ²⁾	4.5 ²⁾	4.5 ²⁾
2.5	<0.5 ¹⁾	<0.5 ¹⁾	0.8	1.5	4.5 ²⁾	4.5 ²⁾	4.5 ²⁾	4.5 ²⁾	4.5 ²⁾	4.5 ²⁾
3.0	<0.5 ¹⁾	<0.5 ¹⁾	0.8	1.4	4.5 ²⁾	4.5 ²⁾	4.5 ²⁾	4.5 ²⁾	4.5 ²⁾	4.5 ²⁾
3.5	<0.5 ¹⁾	<0.5 ¹⁾	0.7	1.3	4.5 ²⁾	4.5 ²⁾	4.5 ²⁾	4.5 ²⁾	4.5 ²⁾	4.5 ²⁾
4	<0.5 ¹⁾	<0.5 ¹⁾	0.6	1.0	3.6	4.5 ²⁾	4.5 ²⁾	4.5 ²⁾	4.5 ²⁾	4.5 ²⁾
5	<0.5 ¹⁾	<0.5 ¹⁾	0.6	0.9	2.0	3.5	4.5 ²⁾	4.5 ²⁾	4.5 ²⁾	4.5 ²⁾
6		<0.5 ¹⁾	0.6	0.9	1.8	3.2	4.5 ²⁾	4.5 ²⁾	4.5 ²⁾	4.5 ²⁾
8		<0.5 ¹⁾	0.5	0.8	1.6	2.6	4.5 ²⁾	4.5 ²⁾	4.5 ²⁾	4.5 ²⁾
10			0.5	0.8	1.4	2.2	3.9	4.5 ²⁾	4.5 ²⁾	4.5 ²⁾
13			0.5	0.7	1.3	2.0	3.6	4.5 ²⁾	4.5 ²⁾	4.5 ²⁾
16				0.6	1.2	1.9	3.2	4.5 ²⁾	4.5 ²⁾	4.5 ²⁾
20					1.2	1.8	3.1	4.4	4.5 ²⁾	4.5 ²⁾
25					1.2	1.8	3.0	4.2	4.5 ²⁾	4.5 ²⁾
32						1.7	2.8	3.9	4.5 ²⁾	4.5 ²⁾
40							2.7	3.8	4.5 ²⁾	4.5 ²⁾
50							2.5	3.5	4.5 ²⁾	4.5 ²⁾
63									4.5 ²⁾	4.5 ²⁾

Short circuit selectivity **Characteristic C** towards fuse link **DII-DIV***)

mMC4	DII-DIV gL/gG									
I_n [A]	10	16	20	25	35	50	63	80	100	
0.75	1.0	4.5 ²⁾	4.5 ²⁾	4.5 ²⁾	4.5 ²⁾	4.5 ²⁾	4.5 ²⁾	4.5 ²⁾	4.5 ²⁾	4.5 ²⁾
1.0	<0.5 ¹⁾	1.2	4.5 ²⁾	4.5 ²⁾	4.5 ²⁾	4.5 ²⁾	4.5 ²⁾	4.5 ²⁾	4.5 ²⁾	4.5 ²⁾
1.5	<0.5 ¹⁾	<0.5 ¹⁾	1.0	2.2	4.5 ²⁾	4.5 ²⁾	4.5 ²⁾	4.5 ²⁾	4.5 ²⁾	4.5 ²⁾
2.0	<0.5 ¹⁾	<0.5 ¹⁾	0.8	1.6	4.5 ²⁾	4.5 ²⁾	4.5 ²⁾	4.5 ²⁾	4.5 ²⁾	4.5 ²⁾
2.5	<0.5 ¹⁾	<0.5 ¹⁾	0.8	1.4	4.5 ²⁾	4.5 ²⁾	4.5 ²⁾	4.5 ²⁾	4.5 ²⁾	4.5 ²⁾
3.0	<0.5 ¹⁾	<0.5 ¹⁾	0.8	0.9	4.5 ²⁾	4.5 ²⁾	4.5 ²⁾	4.5 ²⁾	4.5 ²⁾	4.5 ²⁾
3.5	<0.5 ¹⁾	<0.5 ¹⁾	0.6	0.9	2.2	4.5 ²⁾	4.5 ²⁾	4.5 ²⁾	4.5 ²⁾	4.5 ²⁾
4	<0.5 ¹⁾	<0.5 ¹⁾	0.6	0.8	1.8	3.6	4.5 ²⁾	4.5 ²⁾	4.5 ²⁾	4.5 ²⁾
5	<0.5 ¹⁾	<0.5 ¹⁾	0.6	0.7	1.5	2.7	4.5 ²⁾	4.5 ²⁾	4.5 ²⁾	4.5 ²⁾
6		<0.5 ¹⁾	0.5	0.6	1.4	2.4	4.5 ²⁾	4.5 ²⁾	4.5 ²⁾	4.5 ²⁾
8		<0.5 ¹⁾	<0.5 ¹⁾	0.6	1.3	2.2	4.5 ²⁾	4.5 ²⁾	4.5 ²⁾	4.5 ²⁾
10			<0.5 ¹⁾	0.6	1.3	2.0	3.6	4.5 ²⁾	4.5 ²⁾	4.5 ²⁾
13				0.6	1.3	1.9	3.3	4.5 ²⁾	4.5 ²⁾	4.5 ²⁾
16					1.2	1.8	3.2	4.4	4.5 ²⁾	4.5 ²⁾
20					1.2	1.8	3.1	4.1	4.5 ²⁾	4.5 ²⁾
25						1.7	2.8	3.8	4.5 ²⁾	4.5 ²⁾
32							2.7	3.7	4.5 ²⁾	4.5 ²⁾
40								3.5	4.5 ²⁾	4.5 ²⁾
50									4.5 ²⁾	4.5 ²⁾
63										4.5 ²⁾

¹⁾ Selectivity limit current I_s under 0.5 kA

²⁾ Selectivity limit current I_s = rated breaking capacity I_{cn} of the MCB

Darker areas: no selectivity

Short Circuit Selectivity mMC4 towards D01-D03 fuse link

In case of short circuit, there is selectivity between the miniature circuit breakers mMC4 and the upstream fuses up to the specified values of the selectivity limit current I_s [kA] (i. e. in case of short-circuit currents I_k under I_s only the MCB will trip, in case of short circuit currents above this value both protective devices will respond).

*) basically in accordance with EN 60898-1 D.5.2.b



Short circuit selectivity **Characteristic B** towards fuse link **D01-D03***

Table with 11 columns: mMC4 I_n [A], D01-D03 gL/gG (10, 16, 20, 25, 35, 50, 63, 80, 100). Rows list I_n values from 1.0 to 63.

Short circuit selectivity **Characteristic C** towards fuse link **D01-D03***

Table with 11 columns: mMC4 I_n [A], D01-D03 gL/gG (10, 16, 20, 25, 35, 50, 63, 80, 100). Rows list I_n values from 0.75 to 63.

Short Circuit Selectivity mMC4 towards NH-00 fuse link

In case of short circuit, there is selectivity between the miniature circuit breakers mMC4 and the upstream fuses up to the specified values of the selectivity limit current I_s [kA] (i. e. in case of short-circuit currents I_k under I_s only the MCB will trip, in case of short circuit currents above this value both protective devices will respond).

*) basically in accordance with EN 60898-1 D.5.2.b

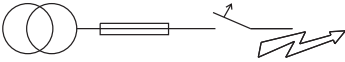

Short circuit selectivity **Characteristic B** towards fuse link **NH-00***

Table with 13 columns: mMC4 I_n [A], NH-00 gL/gG (16, 20, 25, 32, 35, 40, 50, 63, 80, 100, 125, 160). Rows list I_n values from 1.0 to 63.

Short circuit selectivity **Characteristic C** towards fuse link **NH-00***

Table with 13 columns: mMC4 I_n [A], NH-00 gL/gG (16, 20, 25, 32, 35, 40, 50, 63, 80, 100, 125, 160). Rows list I_n values from 0.75 to 63.

SG65212



Description

- High-quality miniature circuit breakers for commercial and household applications
- Contact position indicator red - green
- Guide for secure terminal connection
- 3-position DIN rail clip, permits removal from existing busbar system
- Comprehensive range of accessories suitable for subsequent installation
- Rated currents up to 50 A
- Tripping characteristic C
- Rated breaking capacity 10 kA according to IEC/EN 60947-2
- Up to 250 V DC per pole

Supplied by Digital Stout Innovation & Trading FZE UAE

Miniature Circuit Breakers mCMDC for direct current application

Rated current I_n (A)	Type Designation	Article No.	Units per package
----------------------------	---------------------	-------------	----------------------

10 kA, Characteristic C

SG66212



1-pole

1	mCMDC-C1/1	168552	12/120
2	mCMDC-C2/1	129624	12/120
4	mCMDC-C4/1	129625	12/120
6	mCMDC-C6/1	129626	12/120
10	mCMDC-C10/1	129627	12/120
13	mCMDC-C13/1	129628	12/120
16	mCMDC-C16/1	129629	12/120
20	mCMDC-C20/1	129630	12/120
25	mCMDC-C25/1	129631	12/120
32	mCMDC-C32/1	129632	12/120
40	mCMDC-C40/1	129633	12/120
50	mCMDC-C50/1	129634	12/120

SG66012



2-pole

1	mCMDC-C1/2	168553	1/60
2	mCMDC-C2/2	129635	1/60
3	mCMDC-C3/2	168564	1/60
4	mCMDC-C4/2	129636	1/60
6	mCMDC-C6/2	129637	1/60
10	mCMDC-C10/2	129638	1/60
13	mCMDC-C13/2	129639	1/60
16	mCMDC-C16/2	129640	1/60
20	mCMDC-C20/2	129641	1/60
25	mCMDC-C25/2	129642	1/60
32	mCMDC-C32/2	129643	1/60
40	mCMDC-C40/2	129644	1/60
50	mCMDC-C50/2	129645	1/60

Supplied by Digital Stout Innovations Trading FZE UAE

Specifications | Miniature Circuit Breakers mMCMDC

Description

- High selectivity between MCB and back-up fuse due to low let-through energy
- Compatible with standard busbar
- Twin-purpose terminal (lift/open-mouthed) above and below
- Busbar positioning optionally above or below
- Meets the requirements of insulation co-ordination, distance between contacts ≥ 4 mm, for secure isolation
- Rated breaking capacity 10 kA according to IEC/EN 60947
- Rated voltage to 250 V (per pole), $\tau = 4$ ms
- Take into account polarity!

Accessories:

Auxiliary switch for subsequent installation	ZP-IHK	286052
	ZP-WHK	286053
Tripping signal switch for subsequent installation	ZP-NHK	248437
Remote control and automatic switching device	Z-FW/LP	248296
Shunt trip release	ZP-ASA/..	248438, 248439
Undervoltage release	Z-USA/..	248288-248291
Compact enclosure	KLV-TC-2	276240
	KLV-TC-4	276241
Additional terminal 35 mm ²	Z-HA-EK/35	263960
Switching interlock	Z-IS/SPE-1TE	274418

Technical Data

		mMCMDC
Electrical		
Design according to		IEC/EN 60947-2
Current test marks as printed onto the device		
Rated voltage DC		1-2 A types: 220 V (per pole) 3-50 A types: 250 V (per pole)
Rated frequency		50/60 Hz
Rated breaking capacity according to IEC/EN 60947-2		10 kA
Characteristic		C
Back-up fuse		max. 100 A gL
Selectivity class		3
Rated impulse withstand voltage	U_{imp}	4 kV (1.2/50 μ s)
Endurance		
electrical components		$\geq 4,000$ switching operations
mechanical components		$\geq 20,000$ switching operations
Line voltage connection		at will (above/below)
Mechanical		
Frame size		45 mm
Device height		80 mm
Device width		17.5 mm per pole (1MU)
Mounting		quick fastening with 3 lock-in positions on DIN rail IEC/EN 60715
Degree of protection		IP20
Upper and lower terminals		open mouthed/lift terminals
Terminal protection		finger and hand touch safe, DGUV VS3, EN 50274
Terminal capacity		1-25 mm ²
Terminal torque		2-2.4 Nm
Busbar thickness		0.8 - 2 mm
Mounting		independent of position

Note: not for PV string protection!

Connection diagrams

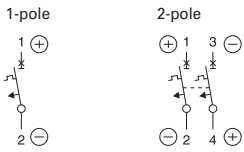

Dimensions (mm)

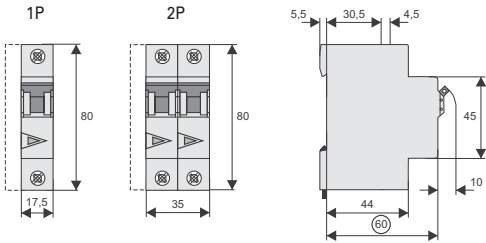

Connection examples

Connection example at 250 V=, 1-pole

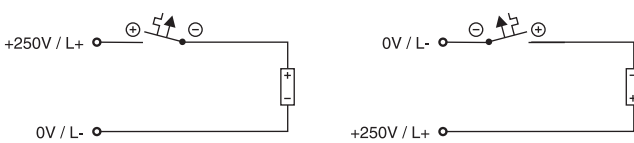

Connection example at 500 V=, 2-pole

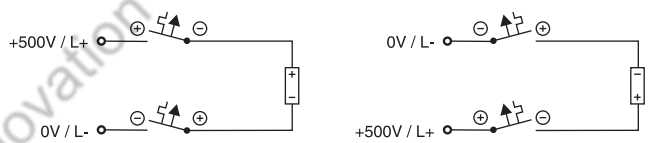

Tripping characteristic mMCMDC

Type C

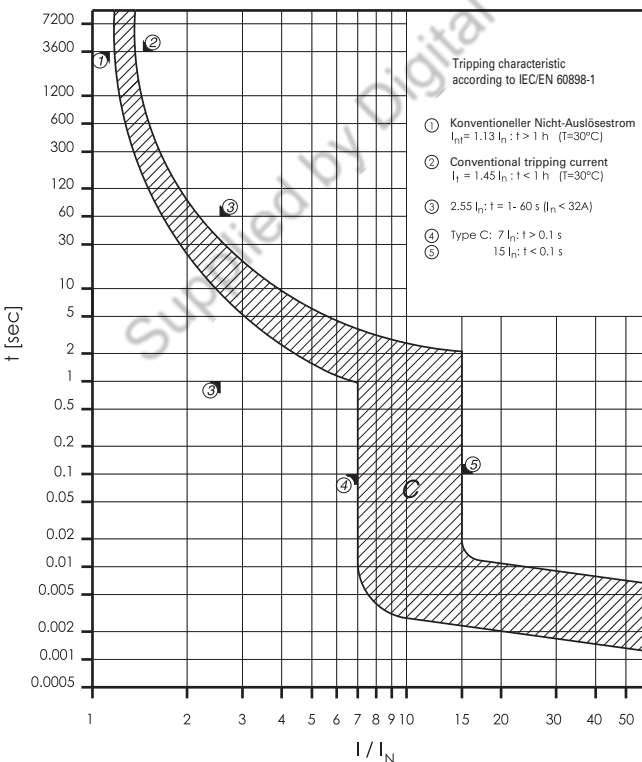

Let-through Energy mMCMDC

Type C, 250 V d.c., $\tau = 5 \text{ ms}$ (according to IEC/EN 60947-2)

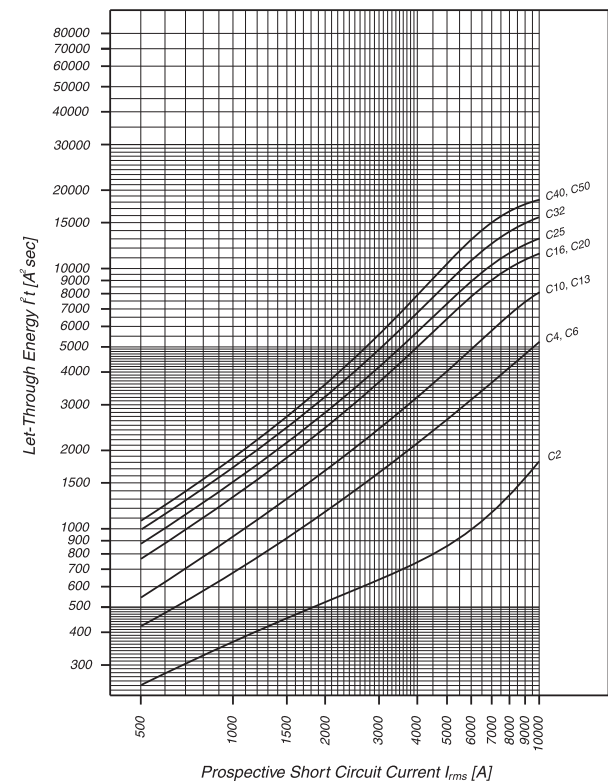

SG04210



Description

- High-quality miniature circuit breakers for commercial and industry applications
- Contact position indicator red - green
- Accessories suitable for subsequent installation
- Rated currents up to 125 A
- Tripping characteristics B, C, D
- Rated breaking capacity up to 25 kA according to EN 60947-2

Supplied by Digital Stout Innovation & Trading FZE UAE

Rated current I_n (A)	Type Designation	Article No.	Units per package
----------------------------	---------------------	-------------	----------------------

25 kA, Characteristic B

SG04010



1-pole

20	mMCT-B20/1	152562	12
25	mMCT-B25/1	152634	12
32	mMCT-B32/1	152563	12
40	mMCT-B40/1	152564	12
50	mMCT-B50/1	152565	12
63	mMCT-B63/1	152635	12
80	mMCT-B80/1	129646	12
100	mMCT-B100/1	129647	12
125	mMCT-B125/1	129648	12

SG05410



2-pole

20	mMCT-B20/2	152704	6
25	mMCT-B25/2	152636	6
32	mMCT-B32/2	152705	6
40	mMCT-B40/2	152706	6
50	mMCT-B50/2	152707	6
63	mMCT-B63/2	152637	6
80	mMCT-B80/2	129654	6
100	mMCT-B100/2	129655	6
125	mMCT-B125/2	129656	6

SG04210



3-pole

20	mMCT-B20/3	152716	4
25	mMCT-B25/3	152638	4
32	mMCT-B32/3	152717	4
40	mMCT-B40/3	152718	4
50	mMCT-B50/3	152719	4
63	mMCT-B63/3	152639	4
80	mMCT-B80/3	129662	4
100	mMCT-B100/3	129663	4
125	mMCT-B125/3	129664	4

SG05610



3+N-pole

20	mMCT-B20/3N	152740	3
25	mMCT-B25/3N	153012	3
32	mMCT-B32/3N	152741	3
40	mMCT-B40/3N	152742	3
50	mMCT-B50/3N	152743	3
63	mMCT-B63/3N	153013	3
80	mMCT-B80/3N	129678	3
100	mMCT-B100/3N	129679	3
125	mMCT-B125/3N	129680	3

SG05510



4-pole

20	mMCT-B20/4	152728	3
25	mMCT-B25/4	153010	3
32	mMCT-B32/4	152729	3
40	mMCT-B40/4	152730	3
50	mMCT-B50/4	152731	3
63	mMCT-B63/4	153011	3
80	mMCT-B80/4	129670	3
100	mMCT-B100/4	129671	3
125	mMCT-B125/4	129672	3

Rated current I_n (A)	Type Designation	Article No.	Units per package
----------------------------	---------------------	-------------	----------------------

25 kA, Characteristic C

SG04010



1-pole

20	mMCT-C20/1	152566	12
25	mMCT-C25/1	158059	12
32	mMCT-C32/1	152567	12
40	mMCT-C40/1	152568	12
50	mMCT-C50/1	152569	12
63	mMCT-C63/1	158310	12
80	mMCT-C80/1	129649	12
100	mMCT-C100/1	129650	12
125	mMCT-C125/1	129651	12

SG05410



2-pole

20	mMCT-C20/2	152708	6
25	mMCT-C25/2	158313	6
32	mMCT-C32/2	152709	6
40	mMCT-C40/2	152710	6
50	mMCT-C50/2	152711	6
63	mMCT-C63/2	158314	6
80	mMCT-C80/2	129657	6
100	mMCT-C100/2	129658	6
125	mMCT-C125/2	129659	6

SG04210



3-pole

20	mMCT-C20/3	152720	4
25	mMCT-C25/3	158317	4
32	mMCT-C32/3	152721	4
40	mMCT-C40/3	152722	4
50	mMCT-C50/3	152723	4
63	mMCT-C63/3	158318	4
80	mMCT-C80/3	129665	4
100	mMCT-C100/3	129666	4
125	mMCT-C125/3	129667	4

SG05610



3+N-pole

20	mMCT-C20/3N	152744	3
25	mMCT-C25/3N	158325	3
32	mMCT-C32/3N	152745	3
40	mMCT-C40/3N	152746	3
50	mMCT-C50/3N	152747	3
63	mMCT-C63/3N	158326	3
80	mMCT-C80/3N	129681	3
100	mMCT-C100/3N	129682	3
125	mMCT-C125/3N	129683	3

SG05510



4-pole

20	mMCT-C20/4	152732	3
25	mMCT-C25/4	158321	3
32	mMCT-C32/4	152733	3
40	mMCT-C40/4	152734	3
50	mMCT-C50/4	152735	3
63	mMCT-C63/4	158322	3
80	mMCT-C80/4	129673	3
100	mMCT-C100/4	129674	3
125	mMCT-C125/4	129675	3

Rated current I_n (A)	Type Designation	Article No.	Units per package
----------------------------	---------------------	-------------	----------------------

25 kA, Characteristic D

SG04010



1-pole

20	mMCT-D20/1	152700	12
25	mMCT-D25/1	158311	12
32	mMCT-D32/1	152701	12
40	mMCT-D40/1	152702	12
50	mMCT-D50/1	152703	12
63	mMCT-D63/1	158312	12
80	mMCT-D80/1	129652	12
100	mMCT-D100/1	129653	12

SG05410



2-pole

20	mMCT-D20/2	152712	6
25	mMCT-D25/2	158315	6
32	mMCT-D32/2	152713	6
40	mMCT-D40/2	152714	6
50	mMCT-D50/2	152715	6
63	mMCT-D63/2	158316	6
80	mMCT-D80/2	129660	6
100	mMCT-D100/2	129661	6

SG04210



3-pole

20	mMCT-D20/3	152724	4
25	mMCT-D25/3	158319	4
32	mMCT-D32/3	152725	4
40	mMCT-D40/3	152726	4
50	mMCT-D50/3	152727	4
63	mMCT-D63/3	158320	4
80	mMCT-D80/3	129668	4
100	mMCT-D100/3	129669	4

SG05610



3+N-pole

20	mMCT-D20/3N	152748	3
25	mMCT-D25/3N	158327	3
32	mMCT-D32/3N	152749	3
40	mMCT-D40/3N	152750	3
50	mMCT-D50/3N	152751	3
63	mMCT-D63/3N	158328	3
80	mMCT-D80/3N	129684	3
100	mMCT-D100/3N	129685	3

SG05510



4-pole

20	mMCT-D20/4	152736	3
25	mMCT-D25/4	158323	3
32	mMCT-D32/4	152737	3
40	mMCT-D40/4	152738	3
50	mMCT-D50/4	152739	3
63	mMCT-D63/4	158324	3
80	mMCT-D80/4	129676	3
100	mMCT-D100/4	129677	3

Specifications | Miniature Circuit Breakers mMCT

Description

- Independent switching contacts
- With isolator function, meets the requirements of insulation co-ordination, distance between contacts ≥ 4 mm, for secure isolation

Accessories:

Auxiliary switch for subsequent installation (0.5 MU)	Z-LHK	248440
Shunt trip release subsequent installation (1.5 MU)	Z-LHASA/230	248442
	Z-LHASA/24	248441
Switching interlock	LH-SPL	285752

Technical Data

		mMCT
Electrical		
Design according to		EN 60947-2
Current test marks as printed onto the device		
Rated voltage	U_n	AC: 230/400 V DC: 60 V (per pole, max. 2 poles)
Ultimate short circuit breaking capacity according to IEC/EN 60947-2		
Characteristic B, C		$I_n = 20-63$ A: 25 kA $I_n = 80-100$ A: 20 kA
Characteristic D		$I_n = 125$ A: 15 kA $I_n = 20-63$ A: 25 kA $I_n = 80$ A: 20 kA $I_n = 100$ A: 15 kA
Characteristic		in accordance with B, C, D
Back-up fuse		max. 200 A gL
Rated insulation voltage	U_i	440 V
Peak withstand voltage	U_{imp}	4 kV
Selectivity class		in accordance with class 3
Endurance		$\geq 20,000$ switching operations
Mechanical		
Frame size		45 mm
Device height		90 mm
Device width		27 mm (1.5MU) per pole
Mounting		quick fastening with 2 lock-in positions on DIN rail IEC/EN 60715
Degree of protection		IP20
Degree of protection, built-in		IP40
Upper and lower terminals		lift terminals
Terminal protection		finger and hand touch safe, DGUV VS3, EN 50274
Terminal capacity		2.5-50 mm ²

Connection diagrams

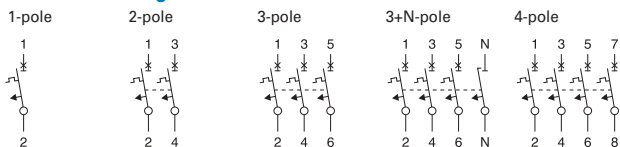

Dimensions (mm)

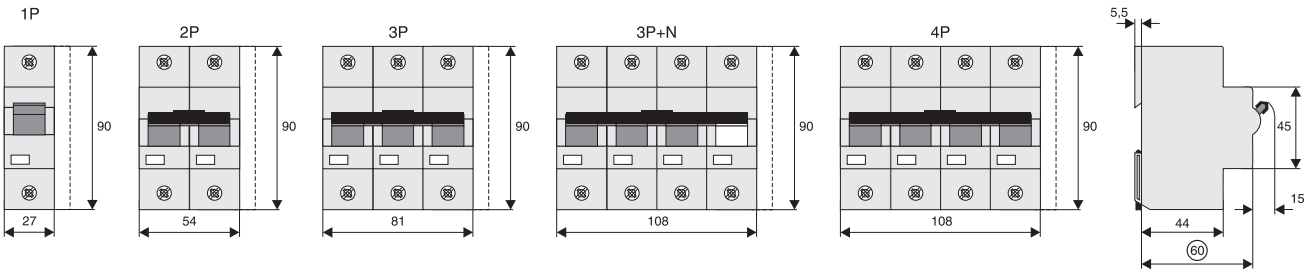

Load Capacity

Load capacity in case of block installation

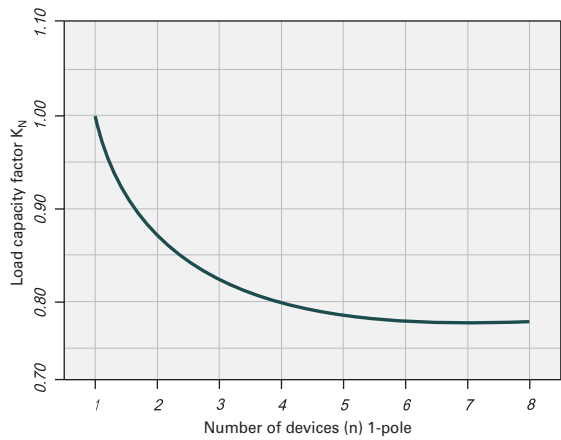

Effect of ambient temperature

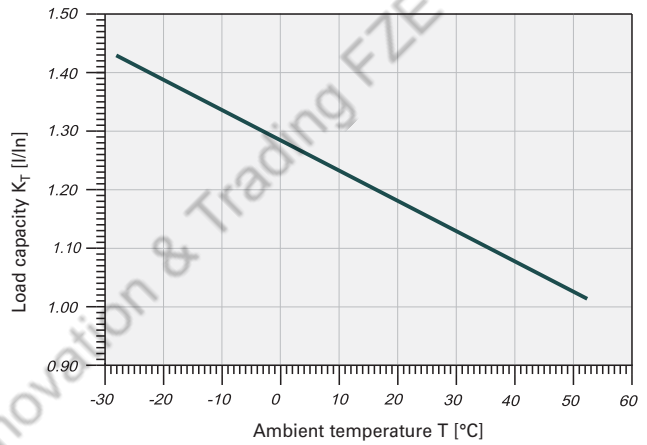

Permitted permanent load at ambient temperature T [°C] with n devices: $I_{DL} = I_n K_T(T) K_N(N)$.

Durchlassenergie

Maximum let-through energy mMCT, Characteristic C, 1-pole

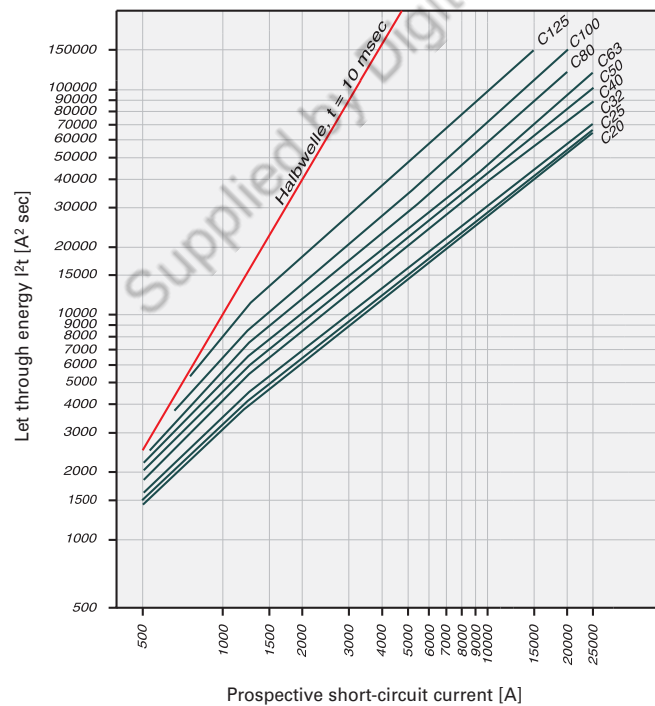

Maximum let-through energy mMCT, Characteristic D, 1-pole

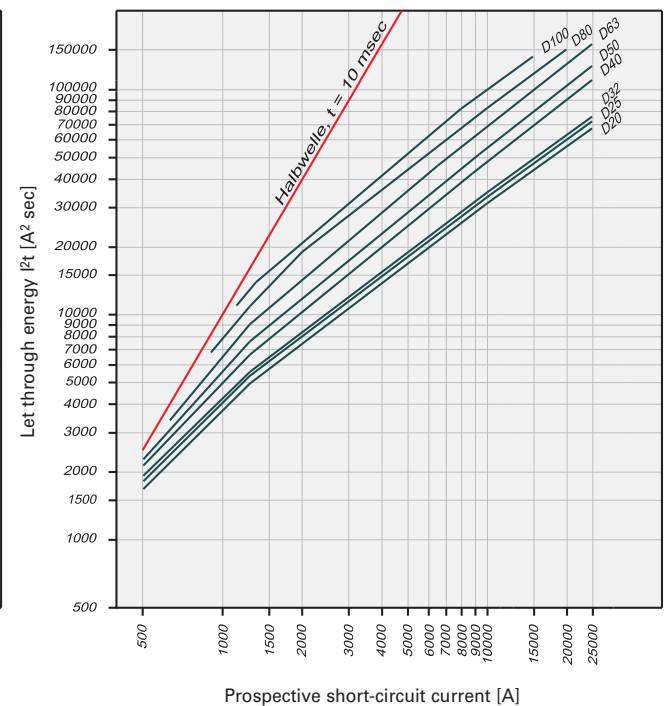

Determined according to 60898-1.

Short Circuit Selectivity mMCT towards D01, D02, D03 and NH size 00

- Short circuit selectivity (in kA) mMCT and upstream fuse D0 or NH, operating class gL/gG
- 1.4 . . . selectivity up to 1.4 kA; Darker areas: no selectivity

Selectivity towards back-up fuses D01, D02, D03

Characteristic C

mMCT I_n [A]	Rated current of the back-up fuse in A gL/gG					
	25	35	50	63	80	100
20	0.5	1.0	2.0	2.9	3.9	7.6
25		1.0	1.9	2.8	3.8	7.3
32		1.0	1.8	2.7	3.6	7.0
40			1.6	2.2	3.0	5.6
50				2.1	2.8	5.2
63					2.7	4.8
80						4.3
100						
125						

Characteristic D

mMCT I_n [A]	Rated current of the back-up fuse in A gL/gG					
	25	35	50	63	80	100
20	0.5	0.9	1.7	2.5	3.4	6.7
25		0.9	1.6	2.3	3.2	6.2
32		0.9	1.5	2.3	3.0	6.0
40			1.4	2.0	2.6	4.7
50				1.8	2.3	4.3
63					2.1	3.7
80						3.1
100						

Selectivity towards back-up fuses NH size 00

Characteristic C

mMCT I_n [A]	Rated current of the back-up fuse in A gL/gG									
	25	35	40	50	63	80	100	125	160	200
20	0.5	1.0	1.3	1.9	2.7	3.7	6.7	17.0	25.0	25.0
25		0.9	1.3	1.8	2.6	3.5	6.5	17.0	25.0	25.0
32		0.9	1.2	1.7	2.4	3.3	6.0	15.0	23.0	25.0
40				1.4	2.1	2.9	4.8	12.0	18.0	25.0
50					1.9	2.7	4.5	11.0	17.0	25.0
63							4.2	10.0	15.0	25.0
80							3.8	8.5	12.0	25.0
100								7.0	10.0	25.0
125									7.5	25.0

Characteristic D

mMCT I_n [A]	Rated current of the back-up fuse in A gL/gG									
	25	35	40	50	63	80	100	125	160	200
20	<0.5	0.8	1.1	1.5	2.3	3.1	5.6	16.0	25.0	25.0
25		0.7	1.0	1.4	2.1	3.0	5.3	14.0	23.0	25.0
32		0.7	1.0	1.3	2.1	2.9	5.0	13.0	22.0	25.0
40				1.1	1.8	2.5	4.2	10.0	15.0	25.0
50					1.6	2.3	3.8	8.5	13.0	22.0
63						2.1	3.2	7.0	10.5	18.0
80							2.8	5.5	8.4	15.0
100								4.8	7.5	12.5

Supplied by Digital Stream Valley & Trading FZE LLC

Short Circuit Selectivity mMCT towards NZM

In case of short circuit, there is selectivity between the miniature circuit breakers mMCT and the upstream NZM up to the specified values of the selectivity limit current I_s [kA] (i. e. in case of short-circuit currents I_{ks} under I_s only the MCB will trip, in case of short circuit currents above this value both protective devices will respond). Overload and short-circuit release unit NZM at max. value.

*) basically in accordance with EN 60898-1 D.5.2.b

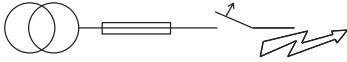

Short circuit selectivity **Characteristic C** towards **NZM1***

mMCT	NZM...1-A gL/gG					
I_n [A]	40	50	63	80	100	125
20	0.3	0.4	0.5	0.75	0.9	1.25
25	0.3	0.4	0.5	0.7	0.9	1.2
32		0.4	0.5	0.7	0.85	1.2
40			0.5	0.6	0.85	1.1
50				0.6	0.85	1.1
63					0.8	1
80						1
100						
125						

Short circuit selectivity **Characteristic D** towards **NZM1***

mMCT	NZM...1-A gL/gG					
I_n [A]	40	50	63	80	100	125
50						
63						
80						
100						

Short circuit selectivity **Characteristic C** towards **NZM2***

mMCT	NZM...2-A gL/gG								
I_n [A]	40	50	63	80	100	125	160	200	250
20	0.3	0.4	0.5	0.75	0.9	1.25	1.8	2.5	3.5
25	0.3	0.4	0.5	0.7	0.9	1.2	1.7	2.4	3.3
32		0.4	0.5	0.7	0.85	1.2	1.65	2.3	3.2
40			0.5	0.6	0.85	1.1	1.5	2.1	2.9
50				0.6	0.85	1.1	1.5	2	2.8
63					0.8	1	1.4	1.8	2.5
80						1	1.4	1.8	2.4
100							1.3	1.7	2.3
125								1.6	2.1

Short circuit selectivity **Characteristic D** towards **NZM2***

mMCT	NZM...2-A gL/gG									
I_n [A]	40	50	63	80	100	125	160	200	250	
50								1	1.4	2.6
63								1	1.3	2.3
80										2.1
100										

¹⁾ Selectivity limit current I_s under 0.5 kA

²⁾ Selectivity limit current I_s = rated breaking capacity I_{cn} of the MCB

Darker areas: no selectivity